

P-6106-1

X505

26425

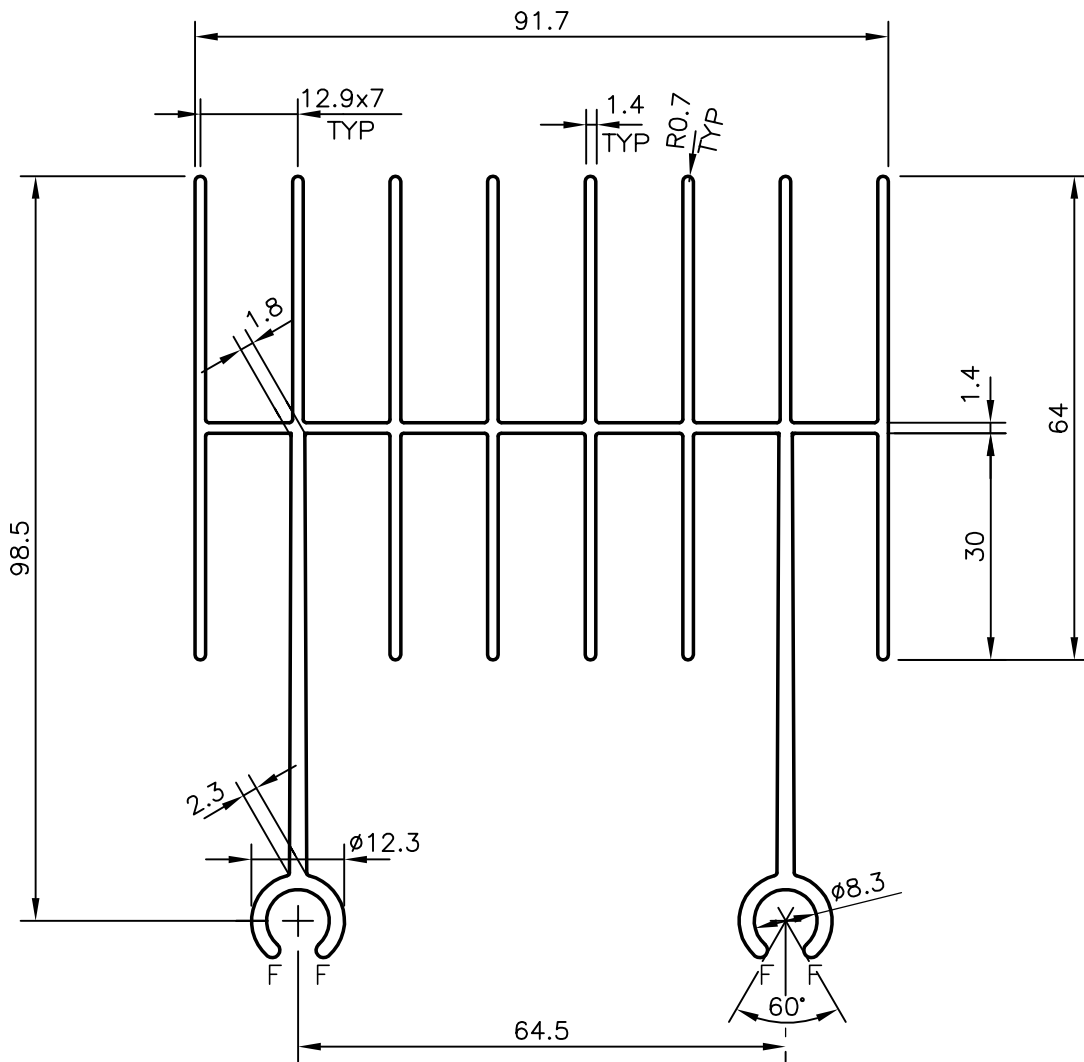

F= FULL RADIUS (4) PLACES



SYMBOL OF QUALITY
AN ISO 9001 COMPANY

JINDAL ALUMINIUM LTD.
BANGALORE-560073 (INDIA)

	NAME	DATE
DRAWN	J.P.KAUSHIK	11-01-2006
CHECKED		
APPROVED		
SCALE		1:1
AREA mm ²		1089.037
PERIMETER mm.		1392.155
WEIGHT kg/m		2.94
DRAWING No.	SECTION No.	
P-6106-1	-	
X505	X505	
26425	26425	

1. ALL DIMENSIONS ARE IN mm.
2. ROUND OFF ALL SHARP CORNERS WITH 0.40 mm.
3. TOLERANCES WILL BE AS PER IS:3965-1981 UNLESS OTHERWISE SPECIFIED

PARTY'S NAME	INDO-WESTERN REFFRIGRATION.,SHAHAPUR
PARTY'S DRAWING No.	0300711-PROTO
ALLOY & TEMPER	HE9 WP
DESCRIPTION	HEATSINK SECTION