

P-6662

S1865

26430

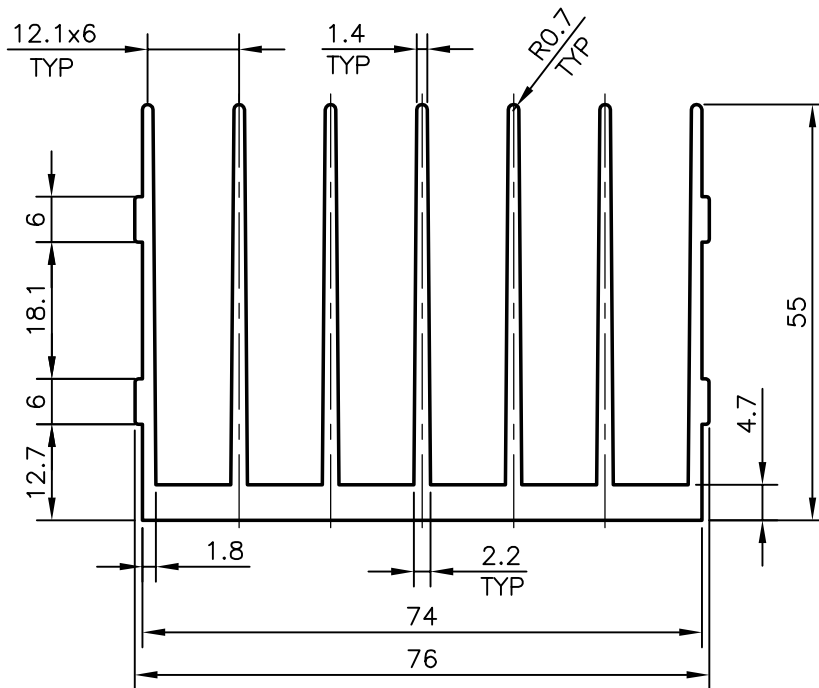

ISSUE-2 FINS HEIGHT INCREASED (3 NO.) AS PER PARTYS REQUIREMENT



SYMBOL OF QUALITY  
AN ISO 9001 COMPANY

**JINDAL ALUMINIUM LTD.**  
BANGALORE-560073 (INDIA)

	NAME	DATE
DRAWN	RAGHAVENDRA	25-01-2007
CHECKED		
APPROVED		

1. ALL DIMENSIONS ARE IN mm.
2. ROUND OFF ALL SHARP CORNERS WITH 0.40 mm.
3. TOLERANCES WILL BE AS PER IS:3965-1981 UNLESS OTHERWISE SPECIFIED

SCALE	1:1
AREA mm <sup>2</sup>	981.479
PERIMETER mm.	859.053
WEIGHT kg/m	2.650

PARTY'S NAME	CONTINENTAL DEVICE INDIA LTD. (DELTRON DEVISION), CHANDIGARH
PARTY'S DRAWING No.	AS PER SAMPLE & AS PER PARTYS REQUIREMENT
ALLOY & TEMPER	6063 T5
DESCRIPTION	HEAT SINK SECTION

DRAWING No.	SECTION No.
P-6662	-
S1865	S1865-ISSUE-2
26430	26430