

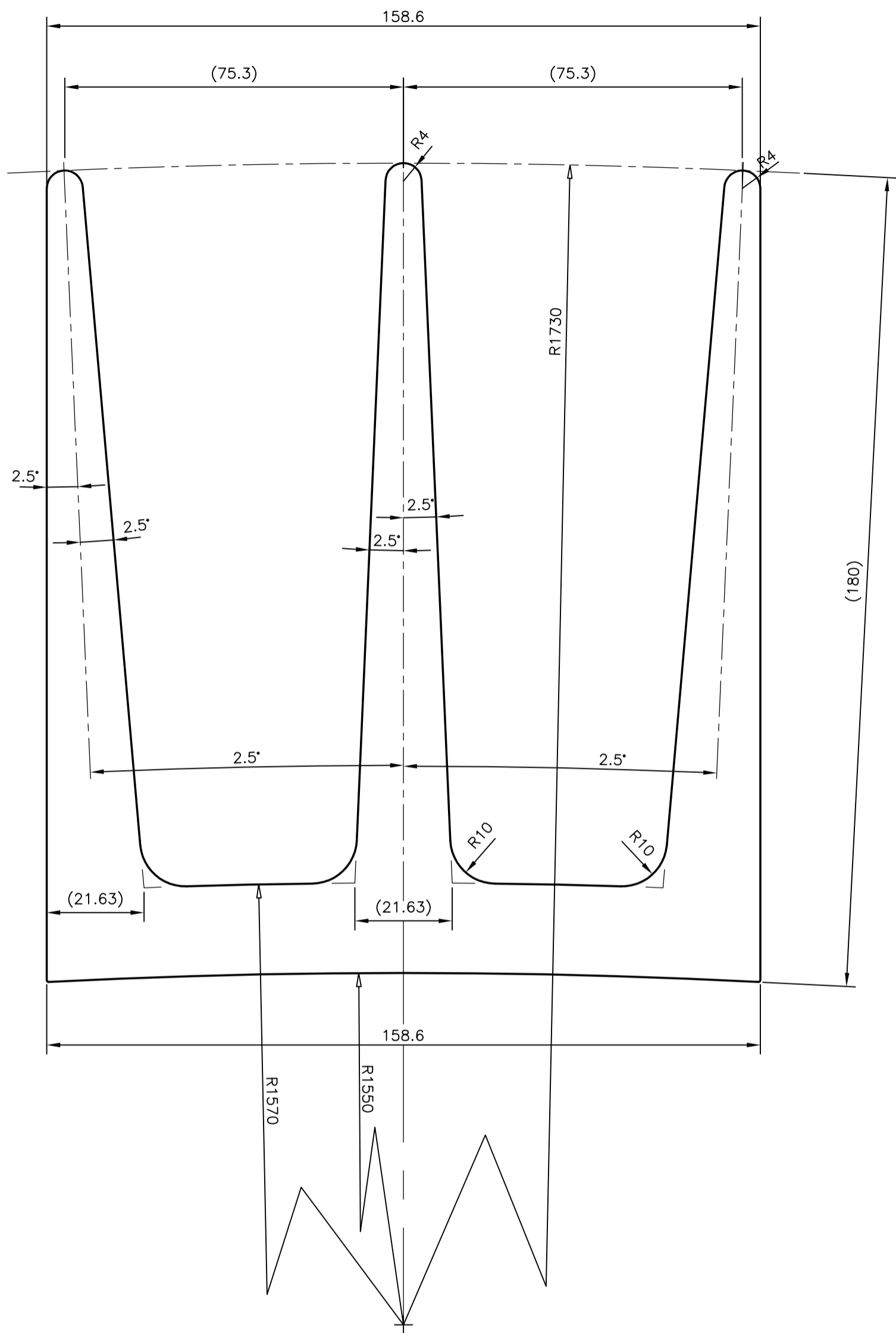

P-9427-1
S2353
26435



 SYMBOL OF QUALITY AN ISO 9001 COMPANY	JINDAL ALUMINIUM LTD. BANGALORE-560073 (INDIA)	DRAWN	J.P.KAUSHIK	20-08-2009
		CHECKED		
1. ALL DIMENSIONS ARE IN mm. 2. ROUND OFF ALL SHARP CORNERS WITH 0.40 mm. 3. TOLERANCES WILL BE AS PER IS:3965-1981 UNLESS OTHERWISE SPECIFIED		APPROVED		
		SCALE	1:1	
PARTY'S NAME LEITNER SHRIRAM MFG. LTD.,TIRUVELLORE		AREA mm ²	10260.333	
		PERIMETER mm.	1251.795	
PARTY'S DRAWING No. 15100845		WEIGHT kg/m	27.703	
		DRAWING No.	SECTION No.	
ALLOY & TEMPER 6060 T6		P-9427-1	-	
		S2353	S2353	
DESCRIPTION HEAT SINK SECTION		26435	26435	