

P-10305-1

S2670

26441

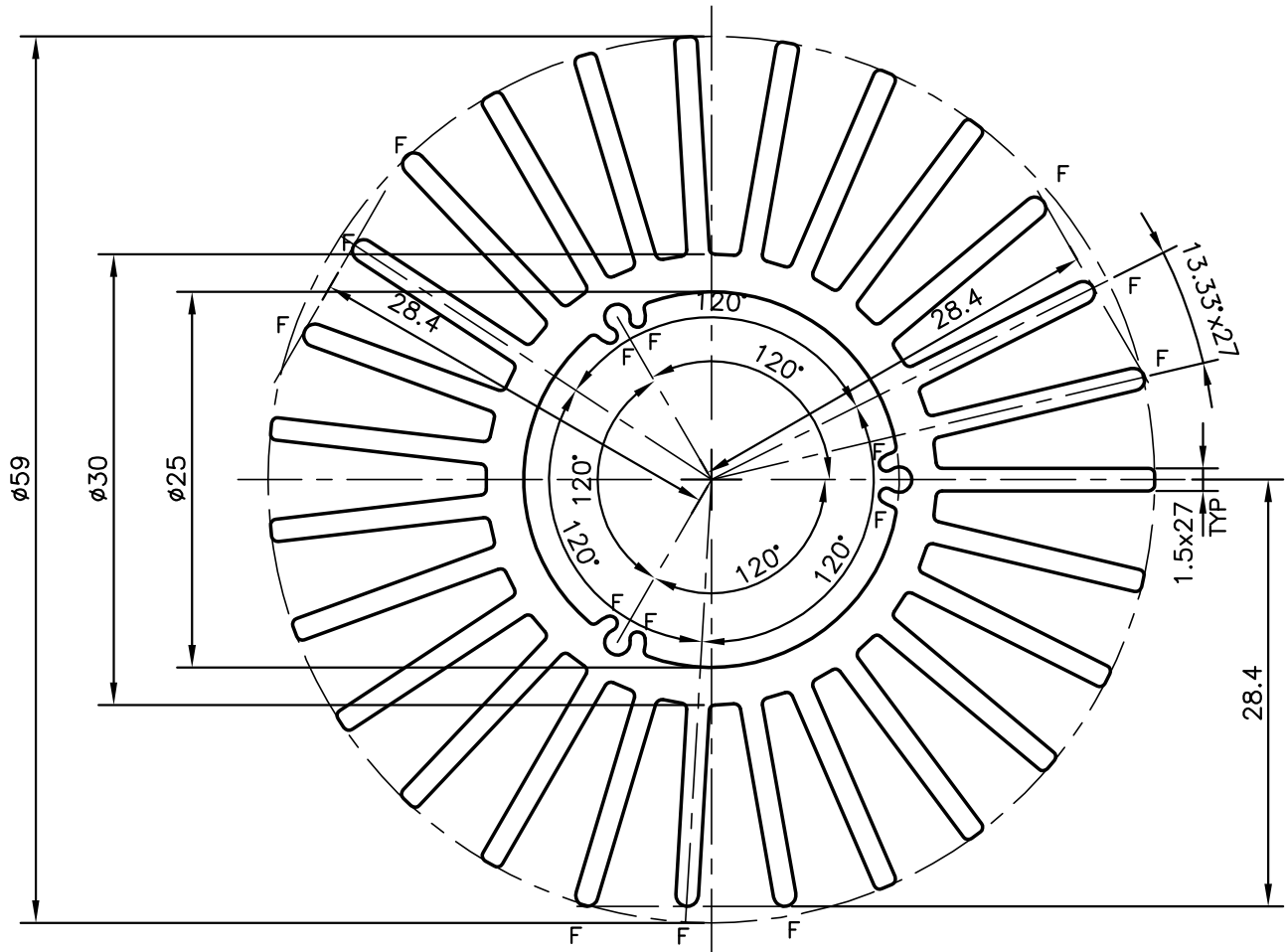
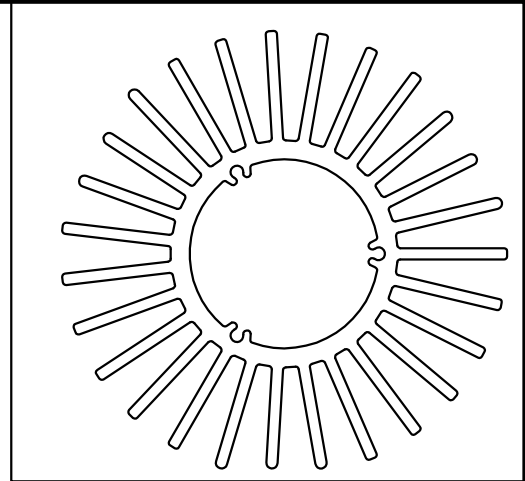
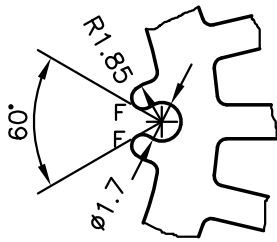

F= FULL RADIUS (15 PLACES)



SYMBOL OF QUALITY
AN ISO 9001 COMPANY

JINDAL ALUMINIUM LTD.
BANGALORE-560073 (INDIA)

	NAME	DATE
DRAWN	J.P.KAUSHIK	17-08-2010
CHECKED		
APPROVED	S.S.GARG	30-08-2010
SCALE		2:1
AREA mm ²		798.404
PERIMETER mm.		848.506
WEIGHT kg/m		2.156
DRAWING No.	SECTION No.	
P-10305-1	-	
S2670	S2670	
26441	26441	

1. ALL DIMENSIONS ARE IN mm.
2. ROUND OFF ALL SHARP CORNERS WITH 0.50 mm.
3. TOLERANCES WILL BE AS PER IS:6477-1983 UNLESS OTHERWISE SPECIFIED

PARTY'S NAME	KROME LED LIGHTING TECHNOLOGIES PVT.LTD., CHENNAI
PARTY'S DRAWING No.	KROME\LED\HSG-001
ALLOY & TEMPER	HE9 WP
DESCRIPTION	HEAT SINK SECTION