

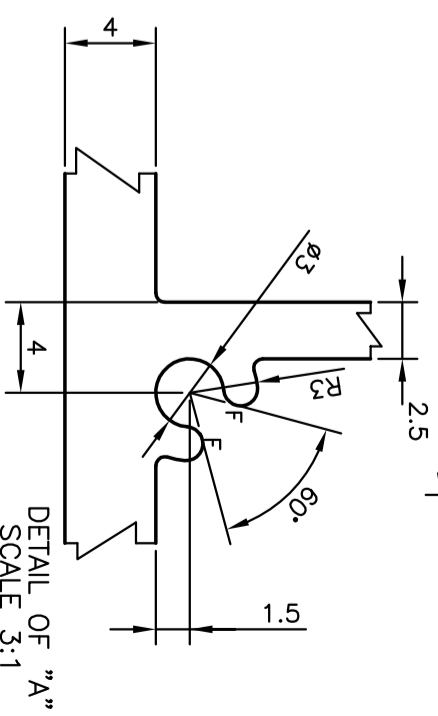

F = FULL RADIUS (26 PLACES)

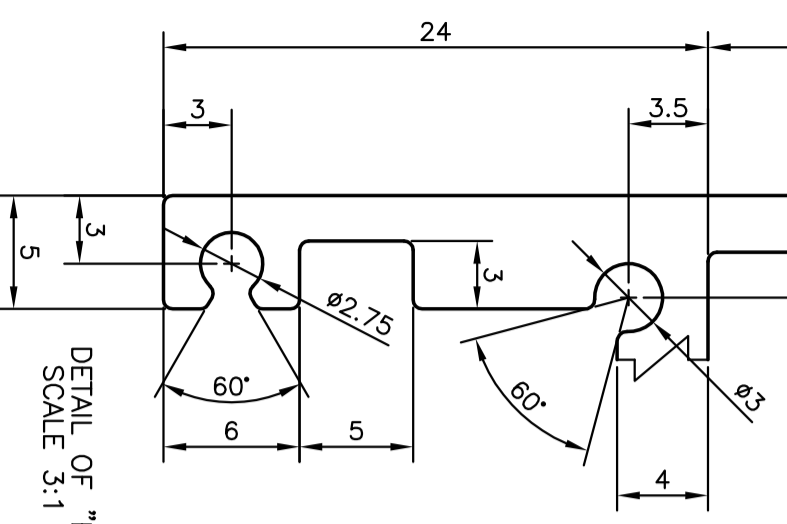

 SYMBOL OF QUALITY AN ISO 9001 COMPANY		JINDAL ALUMINIUM LTD. BANGALORE-560073 (INDIA)	
1. ALL DIMENSIONS ARE IN mm. 2. ROUND OFF ALL SHARP CORNERS WITH 0.40 mm. 3. TOLERANCES WILL BE AS PER IS:6477-1983 UNLESS OTHERWISE SPECIFIED			
PARTY'S NAME		SRICHAKRA SCIENTIFICS, HYDERABAD	
PARTY'S DRAWING No.		AS PER DRAWING	
ALLOY & TEMPER		HE9 WP	
DESCRIPTION		HEAT SINK SECTION	
DRAWN	NAME	DATE	
CHECKED	J.P.KAUSHIK	30-04-2009	
APPROVED			
SCALE	1:1		
AREA mm ²	3537.356		
PERIMETER mm.	2157.871		
WEIGHT kg/m	9.551		
DRAWING No.	P-9192	SECTION No.	-
	S2144		S2144
	26455		26455