

P-10984

S2940

26464

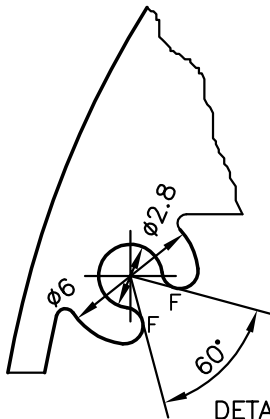
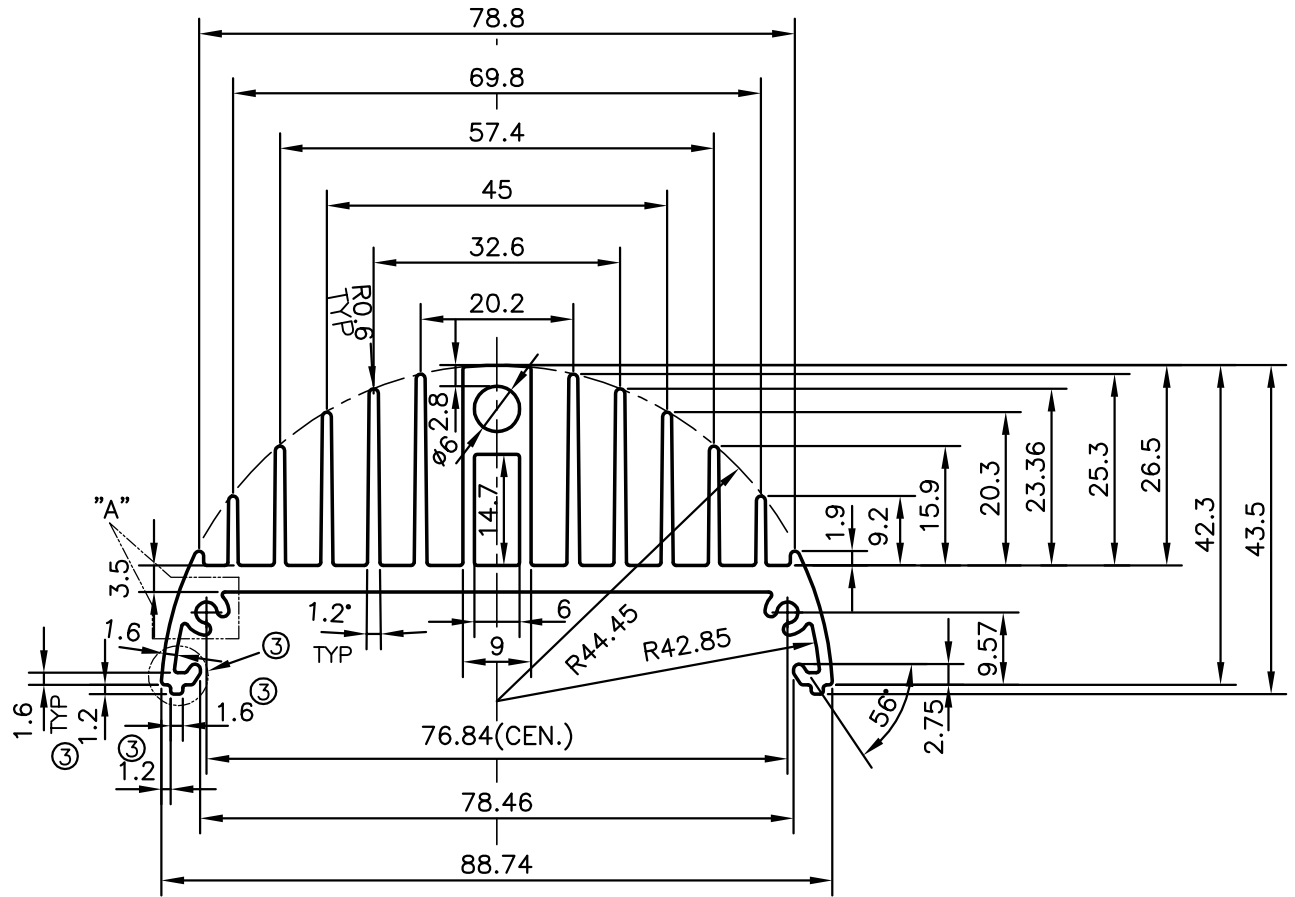

DETAIL OF "A"
SCALE 3:1

ISSUE-2:- SHAPE CHANGED

ISSUE-3:- PROJECTION ADDED

WEIGHT ALSO CHANGED FROM 2.071 kg/M TO 2.082 kg/M

F = FULL RADIUS (4 PLACES)



SYMBOL OF QUALITY
AN ISO 9001 COMPANY

JINDAL ALUMINIUM LTD.
BANGALORE-560073 (INDIA)

| | NAME | DATE |
|----------------------|----------------|------------|
| DRAWN | J.P.KAUSHIK | 05-08-2011 |
| CHECKED | | |
| APPROVED | S.S.GARG | 17-08-2011 |
| SCALE | | 1:1 |
| AREA mm ² | | 771.037 |
| PERIMETER mm. | | 678.946 |
| WEIGHT kg/m | | 2.082 |
| DRAWING No. | SECTION No. | |
| P-10984 | - | |
| S2940 | S2940(ISSUE-3) | |
| 26464 | 26464 | |

1. ALL DIMENSIONS ARE IN mm.
2. ROUND OFF ALL SHARP CORNERS WITH 0.40 mm.
3. TOLERANCES WILL BE AS PER,IS:6477-1983 UNLESS OTHERWISE SPECIFIED

| | |
|---------------------|-------------------------------------|
| PARTY'S NAME | ASIAN RETAIL LIGHTING LTD., CHENNAI |
| PARTY'S DRAWING No. | AS PER DRAWING |
| ALLOY & TEMPER | HE9 WP |
| DESCRIPTION | HEAT SINK SECTION |