

P-11033-1

S2998

26465

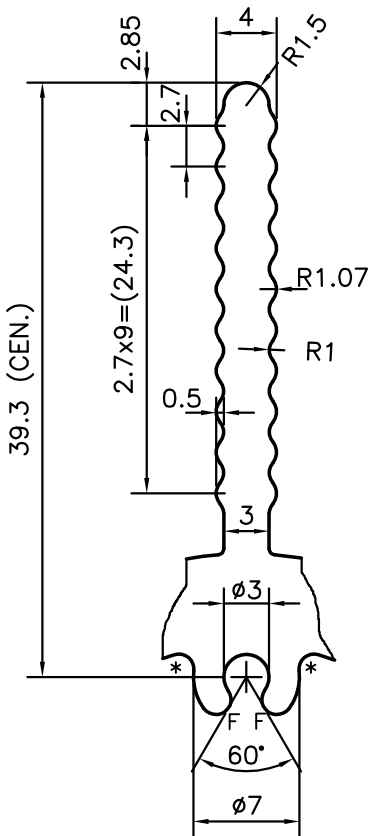
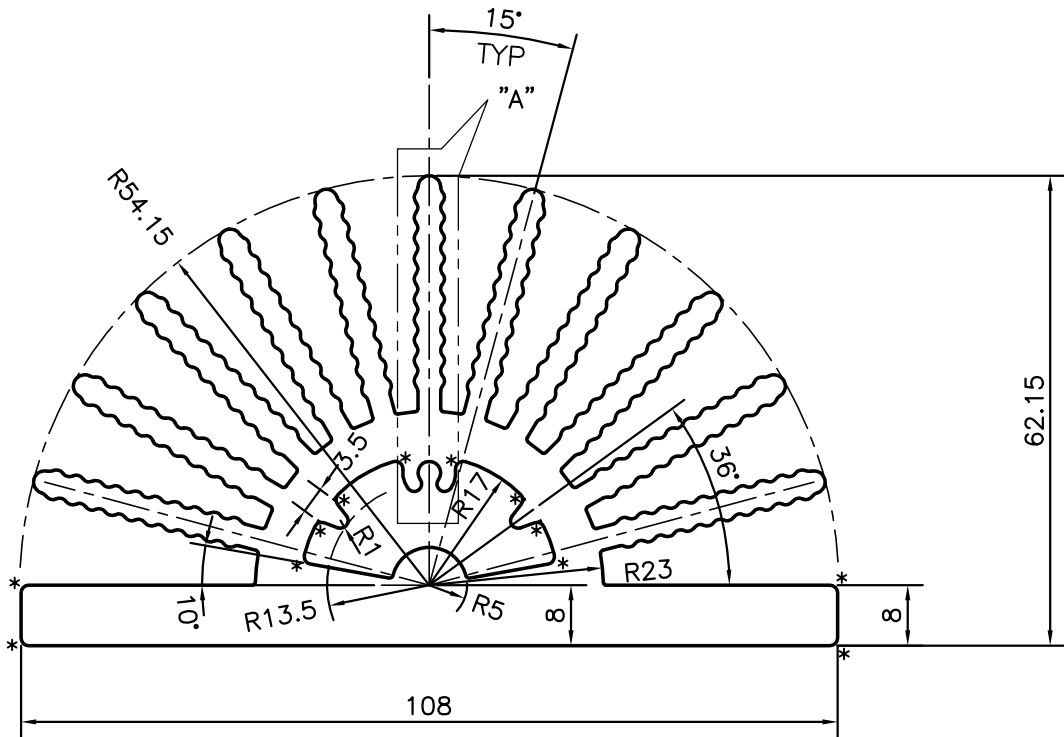

* = R1.0 RADIUS (12 PLACES)
 F = FULL RADIUS (2 PLACES)



SYMBOL OF QUALITY
 AN ISO 9001 COMPANY

JINDAL ALUMINIUM LTD.
 BANGALORE-560073 (INDIA)

	NAME	DATE
DRAWN	J.P.KAUSHIK	07-07-2011
CHECKED		
APPROVED	S.S.GARG	13-07-2011
SCALE		1:1
AREA mm ²		2533.45
PERIMETER mm.		978.128
WEIGHT kg/m		6.840
DRAWING No.	SECTION No.	
P-11033-1	-	
S2998	S2998	
26465	26465	

1. ALL DIMENSIONS ARE IN mm.
2. ROUND OFF ALL SHARP CORNERS WITH 0.40 mm.
3. TOLERANCES WILL BE AS PER, IS:6477-1983 UNLESS OTHERWISE SPECIFIED

PARTY'S NAME	KROME LED LIGHTING TECHNOLOGIES PVT.LTD., CHENNAI
PARTY'S DRAWING No.	AS PER DRAWING
ALLOY & TEMPER	HE9 WP
DESCRIPTION	HEAT SINK SECTION