

P-9707
S2439
26475

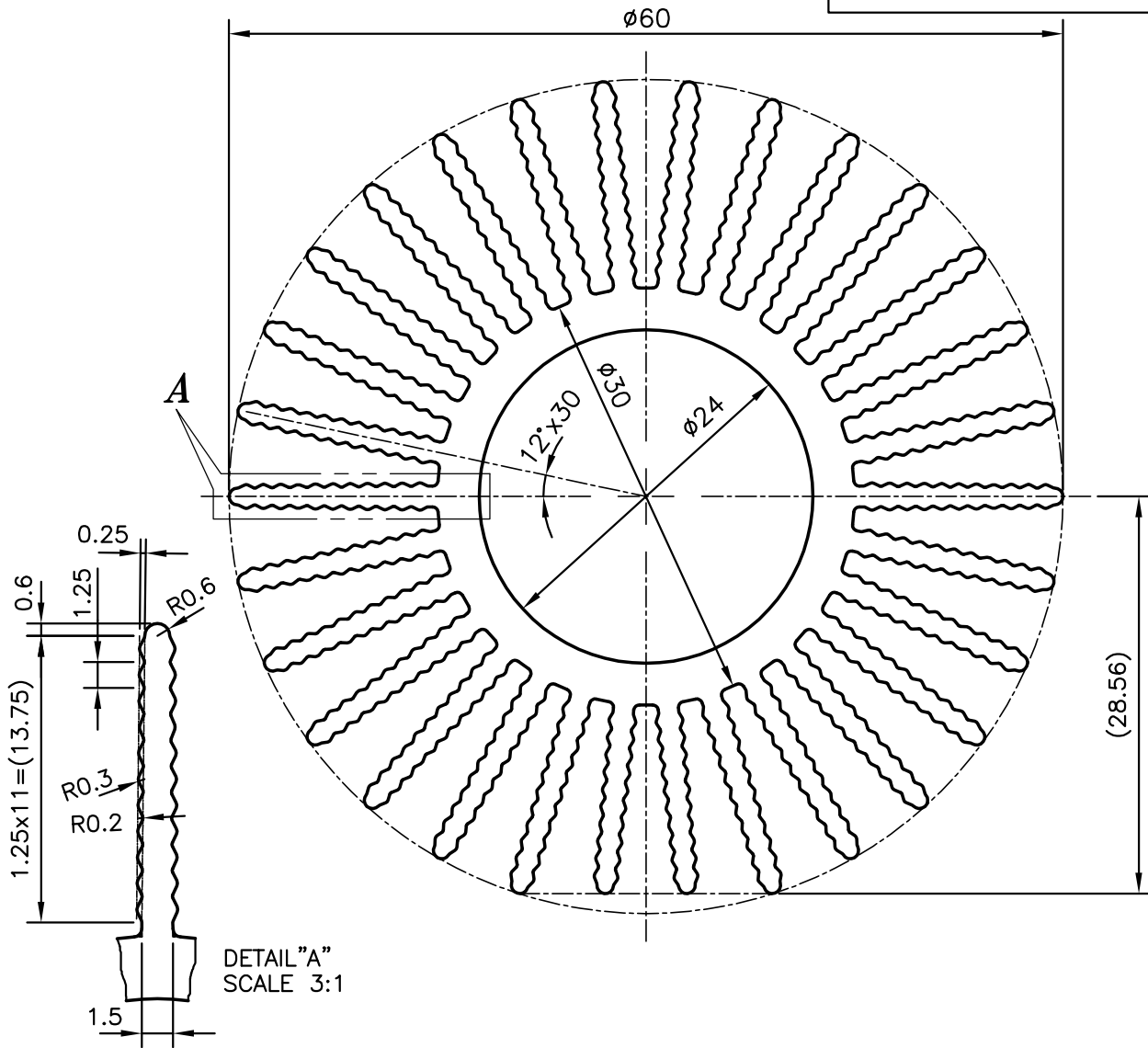

DETAIL "A"
SCALE 3:1

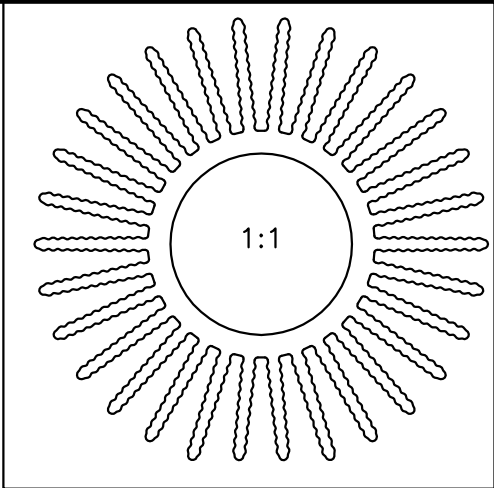

SYMBOL OF QUALITY
AN ISO 9001 COMPANY

JINDAL ALUMINIUM LTD.
BANGALORE-560073 (INDIA)

	NAME	DATE
DRAWN	J.P.KAUSHIK	29-12-2009
CHECKED		
APPROVED		

1. ALL DIMENSIONS ARE IN mm.
2. ROUND OFF ALL SHARP CORNERS WITH 0.40 mm.
3. TOLERANCES WILL BE AS PER IS:6477-1983, UNLESS OTHERWISE SPECIFIED

SCALE	2:1
AREA mm ²	955.073
PERIMETER mm.	1026.149
WEIGHT kg/m	2.579

PARTY'S NAME	QUALITEK ENGINEERS,BANGALORE
PARTY'S DRAWING No.	AS PER DRAWING
ALLOY & TEMPER	HE9 WP
DESCRIPTION	HEAT SINK SECTION

DRAWING No.	SECTION No.
P-9707	-
S2439	S2439
26475	26475