

P-9798
S2468
26478

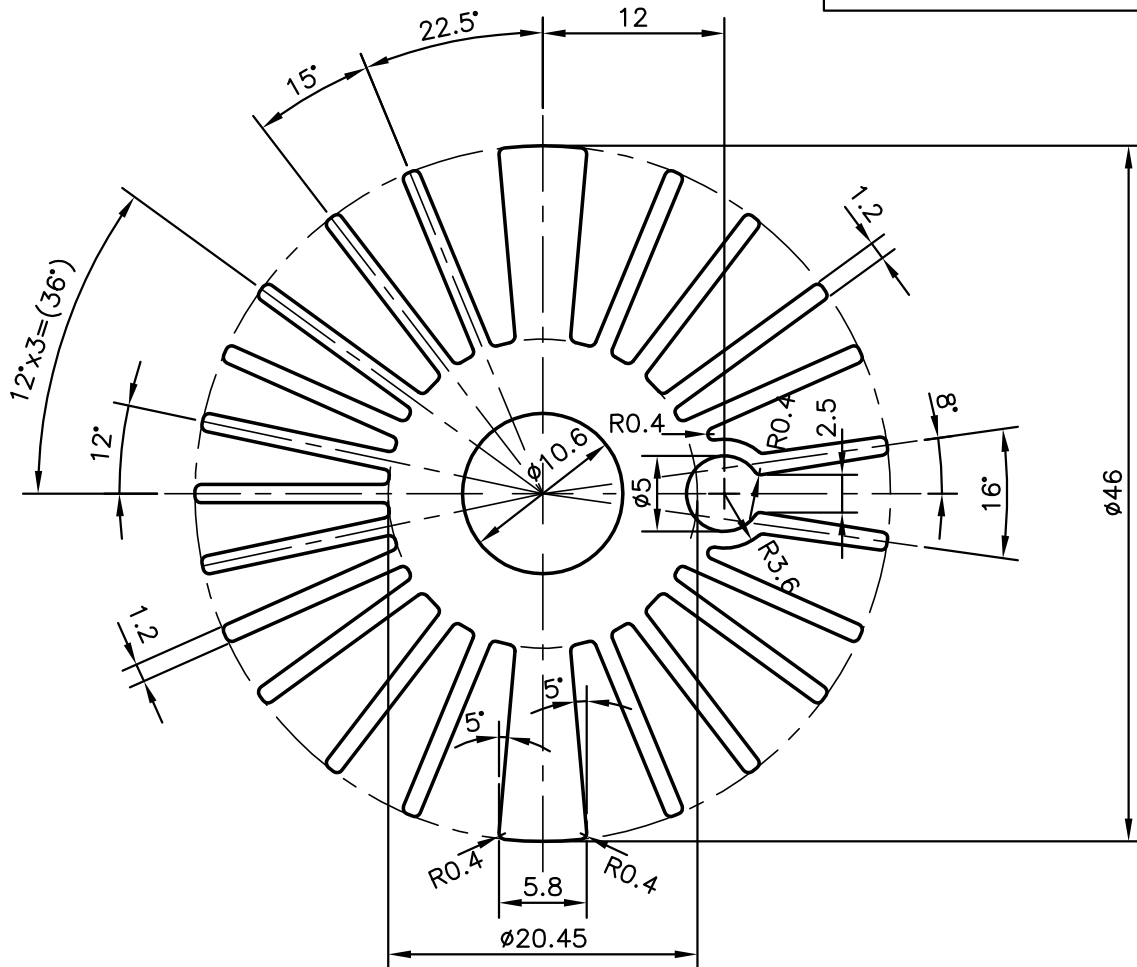
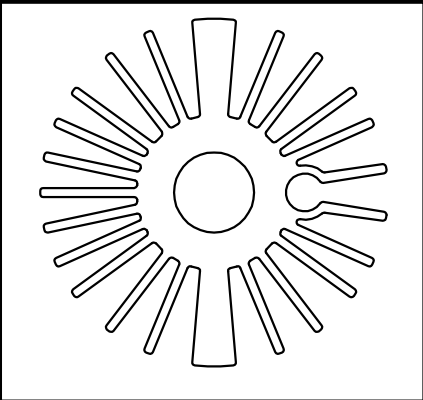

**JINDAL ALUMINIUM LTD.**  
**BANGALORE-560073 (INDIA)**

	NAME	DATE
DRAWN	J.P.KAUSHIK	09-02-2010
CHECKED		
APPROVED	S.S.GARG	02-03-2010
SCALE		2:1
AREA mm <sup>2</sup>		686.058
PERIMETER mm.		640.213
WEIGHT kg/m		1.852
DRAWING No.	SECTION No.	
P-9798	-	
S2468	S2468	
26478	26478	

1. ALL DIMENSIONS ARE IN mm.
2. ROUND OFF ALL SHARP CORNERS WITH 0.40 mm.
3. TOLERANCES WILL BE AS PER IS:6477-1983, UNLESS OTHERWISE SPECIFIED

PARTY'S NAME	P.M. INDUSTRIES, BANGALORE
PARTY'S DRAWING No.	AS PER SAMPLE
ALLOY & TEMPER	HE9 WP
DESCRIPTION	HEAT SINK SECTION