

P-9100-1
S2479
26479

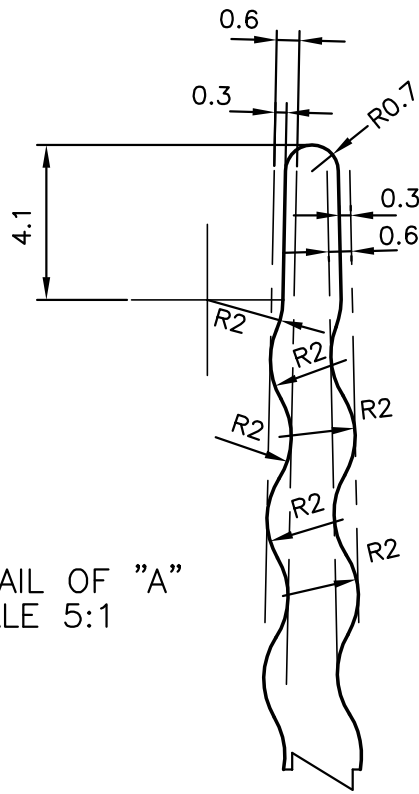

DETAIL OF "A"
SCALE 5:1

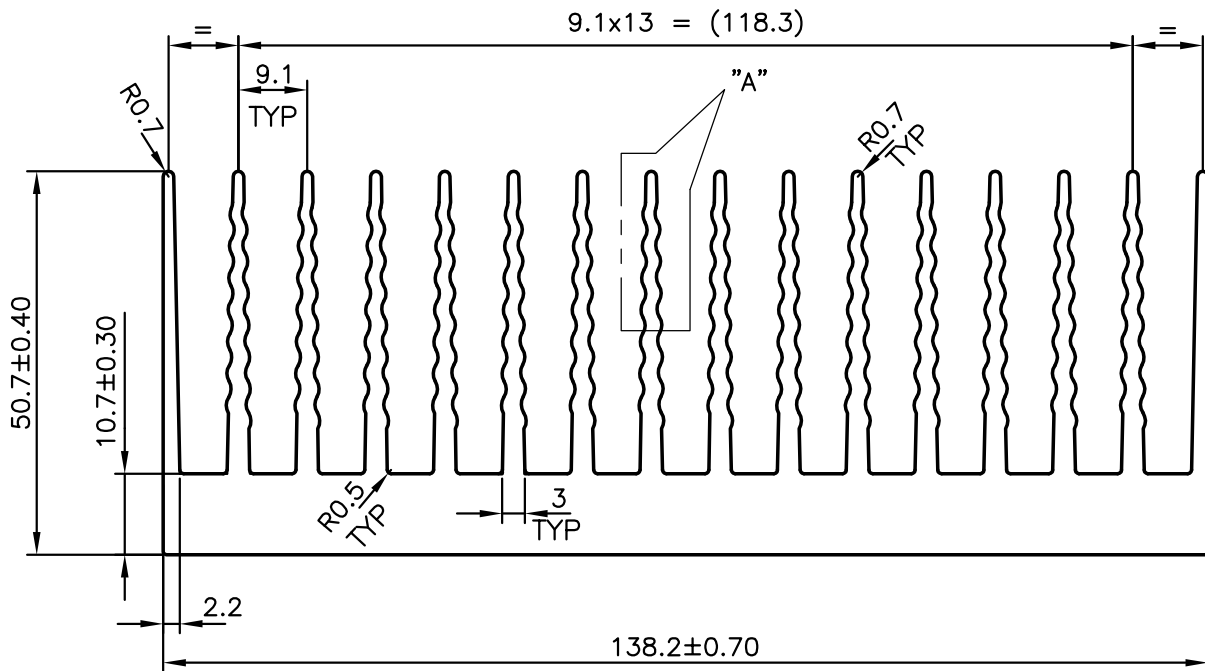

SYMBOL OF QUALITY
AN ISO 9001 COMPANY

JINDAL ALUMINIUM LTD.
BANGALORE-560073 (INDIA)

	NAME	DATE
DRAWN	J.P.KAUSHIK	15-02-2010
CHECKED		
APPROVED	S.S.GARG	03-03-2010
SCALE		1:1
AREA mm ²		2850.521
PERIMETER mm.		1579.856
WEIGHT kg/m		7.696

1. ALL DIMENSIONS ARE IN mm.
2. ROUND OFF ALL SHARP CORNERS WITH 0.40 mm.
3. TOLERANCES WILL BE AS PER IS:3965-1981, UNLESS OTHERWISE SPECIFIED

PARTY'S NAME	AAVID THERMALLOY INDIA (P) LTD., VADODARA
PARTY'S DRAWING No.	SY 78 (I)
ALLOY & TEMPER	6063 T5
DESCRIPTION	HEATSINK SECTION

DRAWING No.	SECTION No.
P-9100-1	-
S2479	S2479
26479	26479