

P-10210-2

S2645

26489

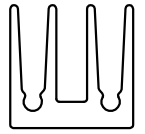

1:1

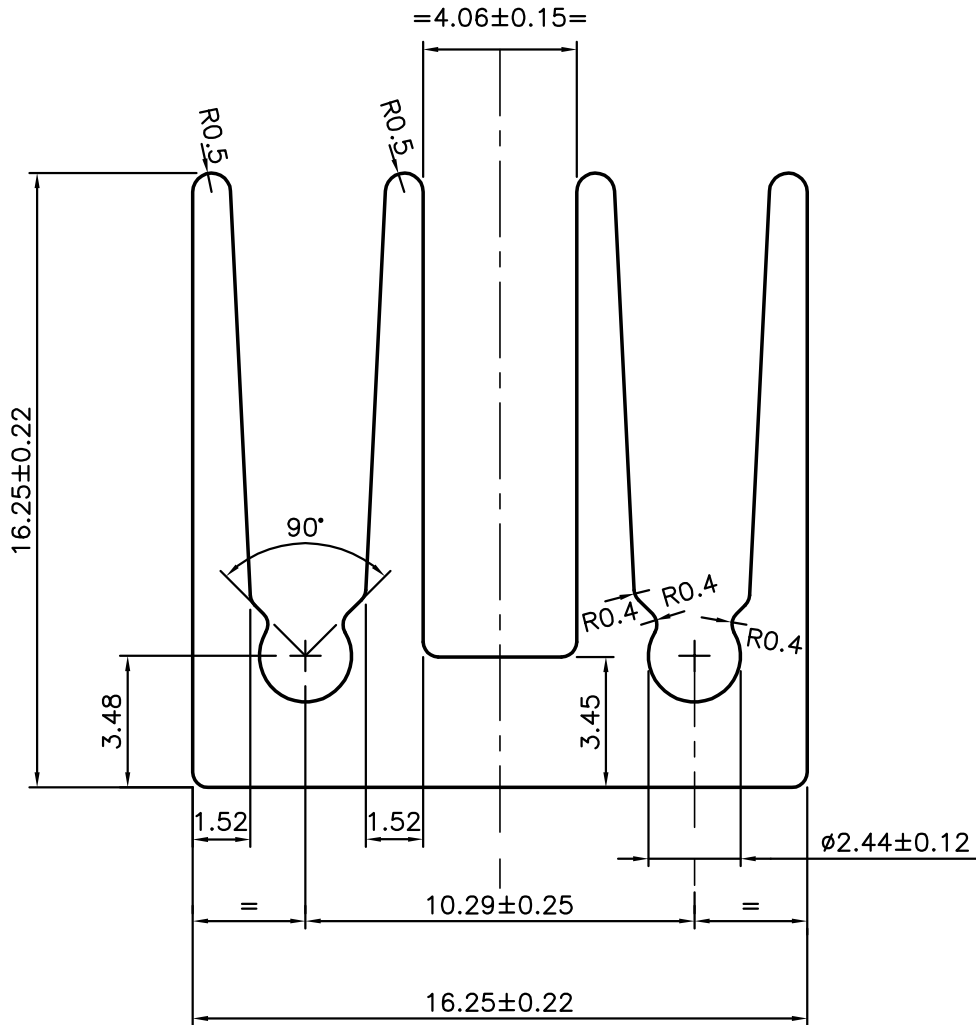

SYMBOL OF QUALITY
AN ISO 9001 COMPANY

JINDAL ALUMINIUM LTD.
BANGALORE-560073 (INDIA)

	NAME	DATE
DRAWN	J.P.KAUSHIK	04-08-2010
CHECKED		
APPROVED	S.S.GARG	17-08-2010

1. ALL DIMENSIONS ARE IN mm.
2. ROUND OFF ALL SHARP CORNERS WITH 0.40 mm.
3. TOLERANCES WILL BE AS PER BS:EN-12020-2 UNLESS OTHERWISE SPECIFIED

SCALE	5:1
AREA mm ²	119.188
PERIMETER mm.	139.715
WEIGHT kg/m	0.322

PARTY'S NAME	AAVID THERMALLOY INDIA PVT. LTD.,VADODARA
PARTY'S DRAWING No.	62470
ALLOY & TEMPER	6063 T5
DESCRIPTION	HEAT SINK SECTION

DRAWING No.	SECTION No.
P-10210-2	-
S2645	S2645
26489	26489