

S130
7853
26544

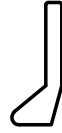

1:1

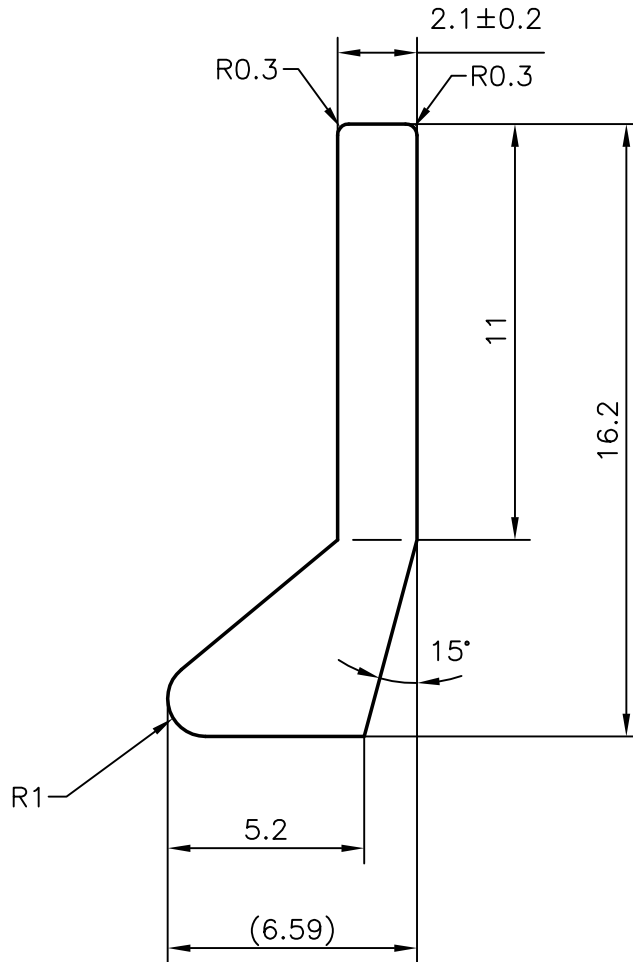

JINDAL ALUMINIUM LTD.
BANGALORE-560073

| | | |
|-------------|------------|----------|
| | NAME | DATE |
| DRAWN | R.D.Sharma | 03-12-96 |
| CHECKED | | |
| APPROVED | | |
| SCALE | 5:1 | |
| WEIGHT kg/m | 0.122 | |
| SECTION No. | 26544 | |
| DRAWING No. | 26544 | |

1. ALL DIMENSIONS ARE IN mm.
2. ROUND OFF ALL SHARP CORNERS WITH 0.4 mm.
3. TOLERANCES WILL BE AS PER IS: 3965-1981 ,UNLESS OTHERWISE SPECIFIED

| | |
|---------------------|-----------------------------------|
| PARTY'S NAME | BEST ALUMINIUM COMPANY, BANGALORE |
| PARTY'S DRAWING No. | JUC-FAB-ACG-003 |
| ALLOY & TEMPER | HE9 WP |
| LENGTH | 3658 mm. |
| DESCRIPTION | GRILL SECTION |