

7877

26556

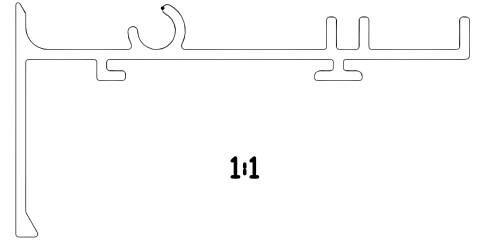

1:1

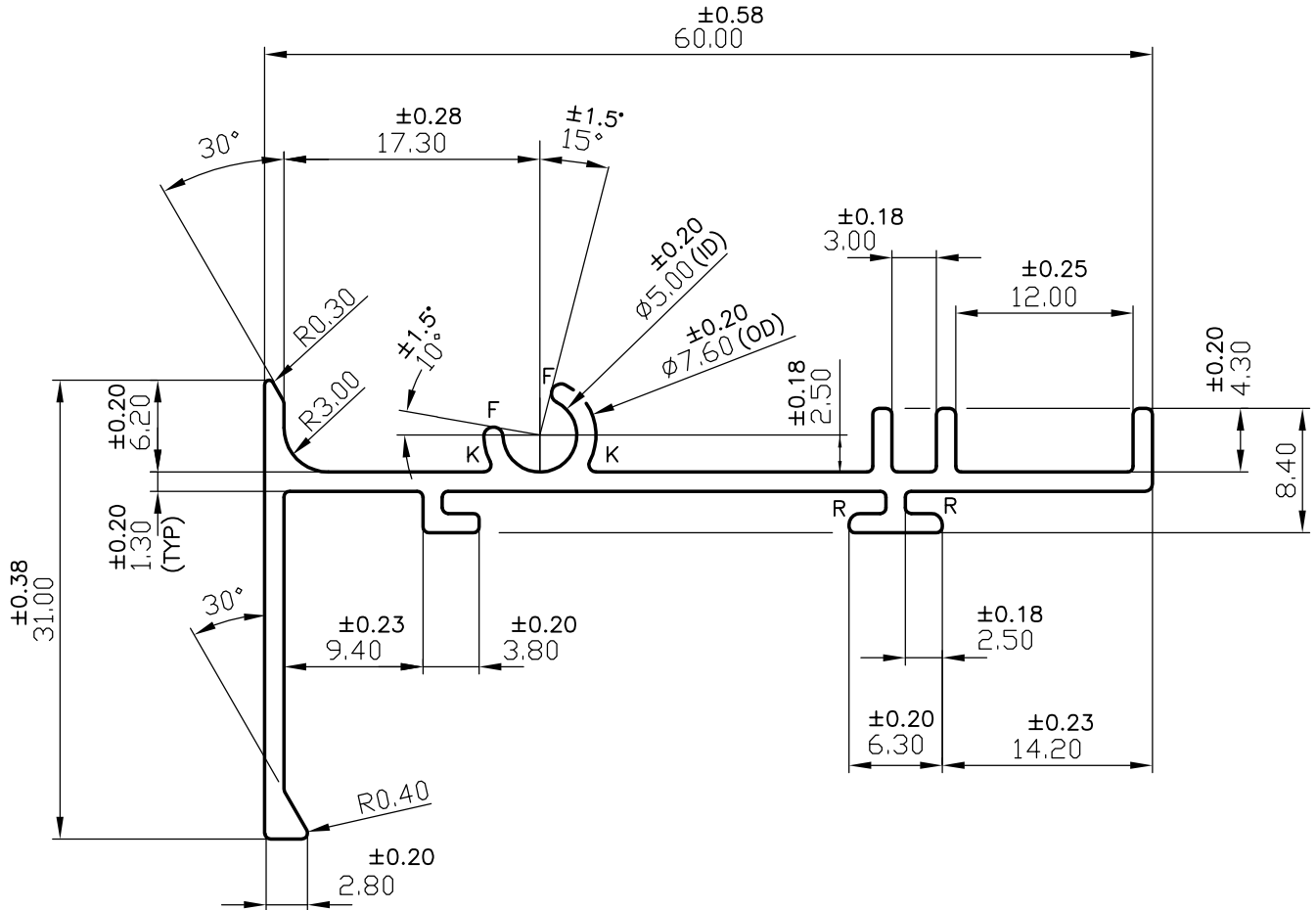

GENERAL WALL THICKNESS  $\pm 0.20$  1.30 mm

R = RADII 0.75 (2)

K = RADII 0.50 (2)

F = FULL RADII (2)



SYMBOL OF QUALITY  
AN ISO 9002 COMPANY

**JINDAL ALUMINIUM LTD.**  
BANGALORE-560073 (INDIA)

	NAME	DATE
DRAWN	P,KULKARNI	28-12-99
CHECKED		
APPROVED		

1. ALL DIMENSIONS ARE IN mm.
2. ROUND OFF ALL SHARP CORNERS WITH 0.40 mm.
3. TOLERANCES WILL BE AS PER BS:1474-1987 UNLESS OTHERWISE SPECIFIED

PARTY'S NAME	<b>AIR MASTER EQUIPMENTS EMIRATES LLC.,</b>		SCALE	2:1
PARTY'S DRAWING No.	<b>AS PER SKETCH</b>		WEIGHT kg/m	0.454
ALLOY & TEMPER	<b>6063 T6</b>	LENGTH: 5850 mm	SECTION No.	26556
DESCRIPTION	<b>SLOT FRAME</b>		DRAWING No.	26556