

7878

26557

-

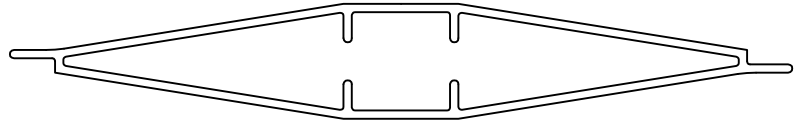

WITHOUT DIME'S
(1:1)

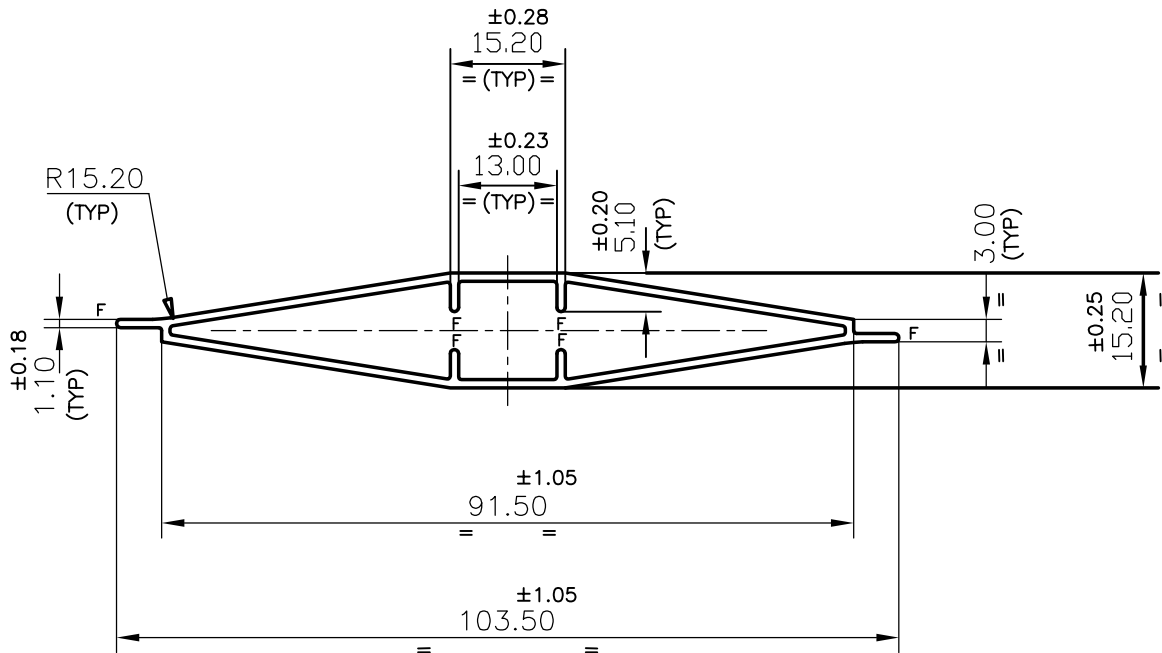

±0.18
GENERAL WALL THICKNESS 1.10 mm
F = FULL RADII (6)



SYMBOL OF QUALITY
AN ISO 9002 COMPANY

JINDAL ALUMINIUM LTD.
BANGALORE-560073 (INDIA)

	NAME	DATE
DRAWN	P,KULKARNI	21-12-99
CHECKED		
APPROVED		

1. ALL DIMENSIONS ARE IN mm.
2. ROUND OFF ALL SHARP CORNERS WITH 0.40 mm.
3. TOLERANCES WILL BE AS PER BS:1467-1987 UNLESS OTHERWISE SPECIFIED

PARTY'S NAME	AIR MASTER EQUIPMENTS EMIRATES LLC.		SCALE	1:1
PARTY'S DRAWING No.	AS PER SKETCH (AS PER OUR (P) No P-2488)		WEIGHT kg/m	0.637
ALLOY & TEMPER	6063 T6	LENGTH: 5850 mm	SECTION No.	26557
DESCRIPTION	V C D BLADE.		DRAWING No.	26557