

S434

7908

26579

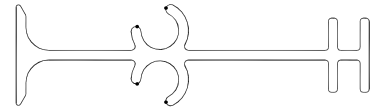

1:1

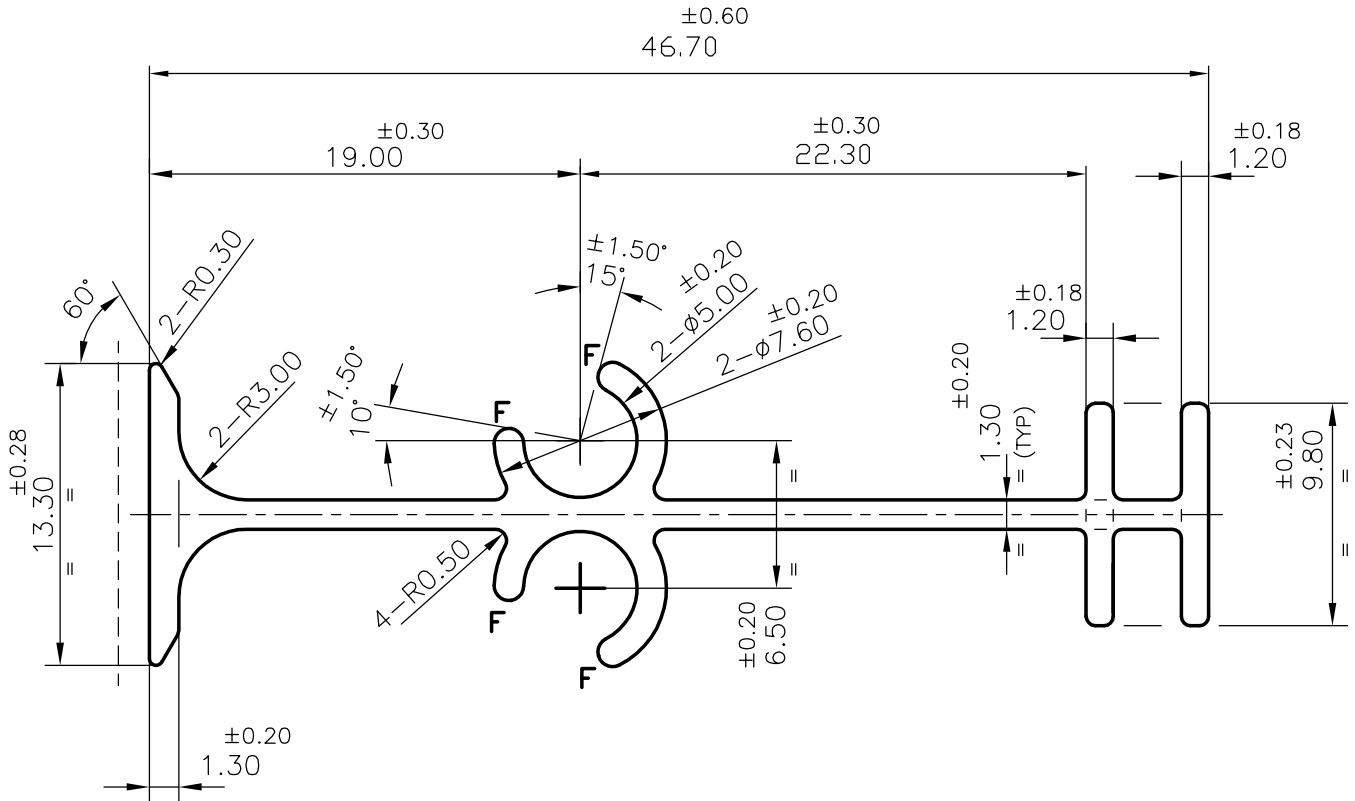

STRAIGHTNESS 1.70 mm/METER OF LENGTH

F = RADII FULL (4)

----- EXPOSED SURFACE



SYMBOL OF QUALITY
AN ISO 9002 COMPANY

JINDAL ALUMINIUM LTD.

BANGALORE-560073 (INDIA)

NAME

DATE

DRAWN

P,KULKARNI

30-11-99

CHECKED

APPROVED

SCALE

3:1

PARTY'S NAME

S.S. INDUSTRIES., BANGALORE

WEIGHT kg/m

0.345

PARTY'S DRAWING No.

DIRECT APPROVED TO OUR DRG No. P-2538-1

SECTION No.

26579

ALLOY & TEMPER

HE9 WP

LENGTH: 3658 mm

DRAWING No.

DESCRIPTION

AIR GRILL SECTION

26579

1. ALL DIMENSIONS ARE IN mm.
2. ROUND OFF ALL SHARP CORNERS WITH 0.40 mm.
3. TOLERANCES WILL BE AS PER IS 3965-1981 UNLESS OTHERWISE SPECIFIED