

P-2922
7920
26588

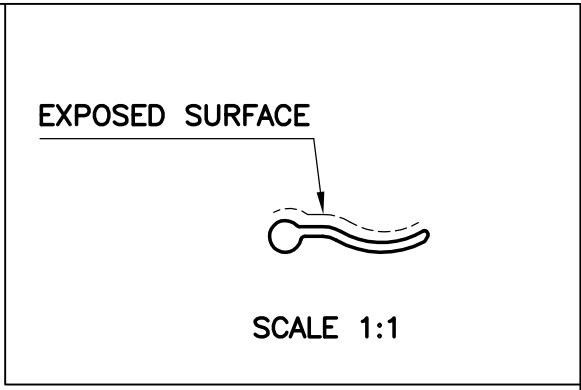

SCALE 8:1

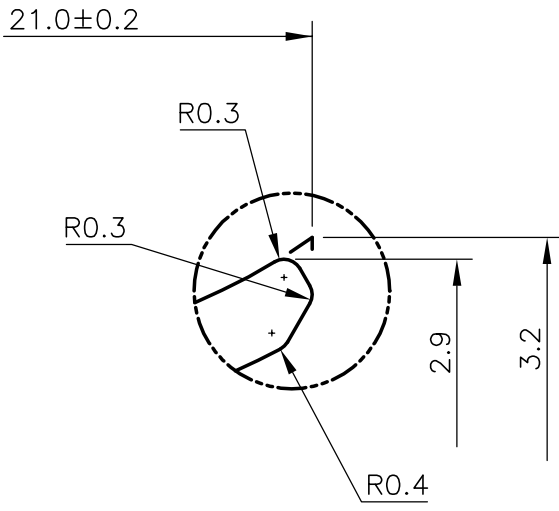
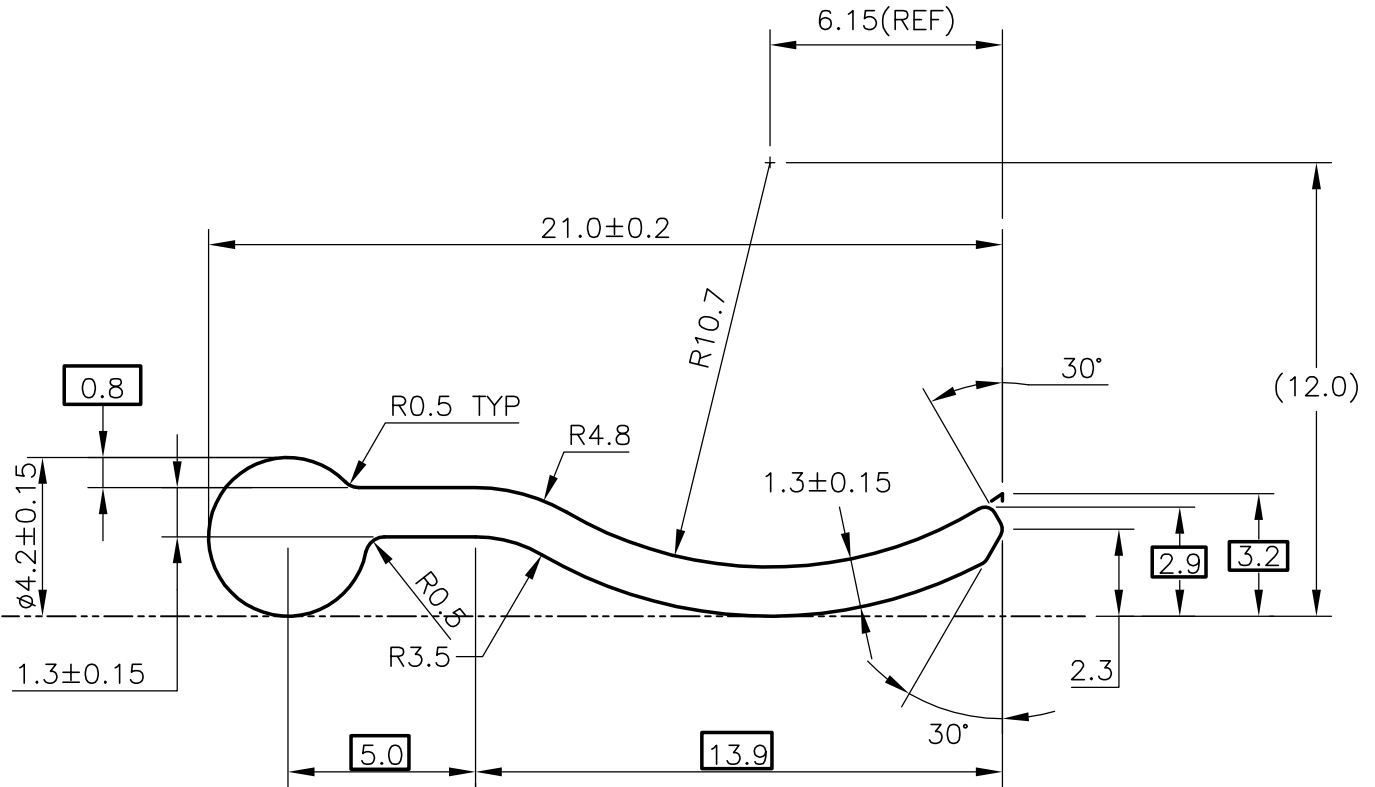

JINDAL ALUMINIUM LTD.
BANGALORE-560073 (INDIA)

	NAME	DATE
DRAWN	RANGASWAMY	15-9-2K
CHECKED		
APPROVED		
SCALE	5:1	
WEIGHT kg/m	0.099	
SECTION No.	26588	
DRAWING No.	26588	

1. ALL DIMENSIONS ARE IN mm. 2. ROUND OFF ALL SHARP CORNERS WITH 0.40 mm. 3. TOLERANCES WILL BE AS PER BS:1474-1987 UNLESS OTHERWISE SPECIFIED	
PARTY'S NAME	TECNALCO. UMM AL QUWAN UAE.
PARTY'S DRAWING No.	AS PER SKETCH
ALLOY & TEMPER	HE9 WP (6063 T6)
DESCRIPTION	AIR GRILL SECTION