

S376

7932

26592

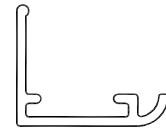

1:1

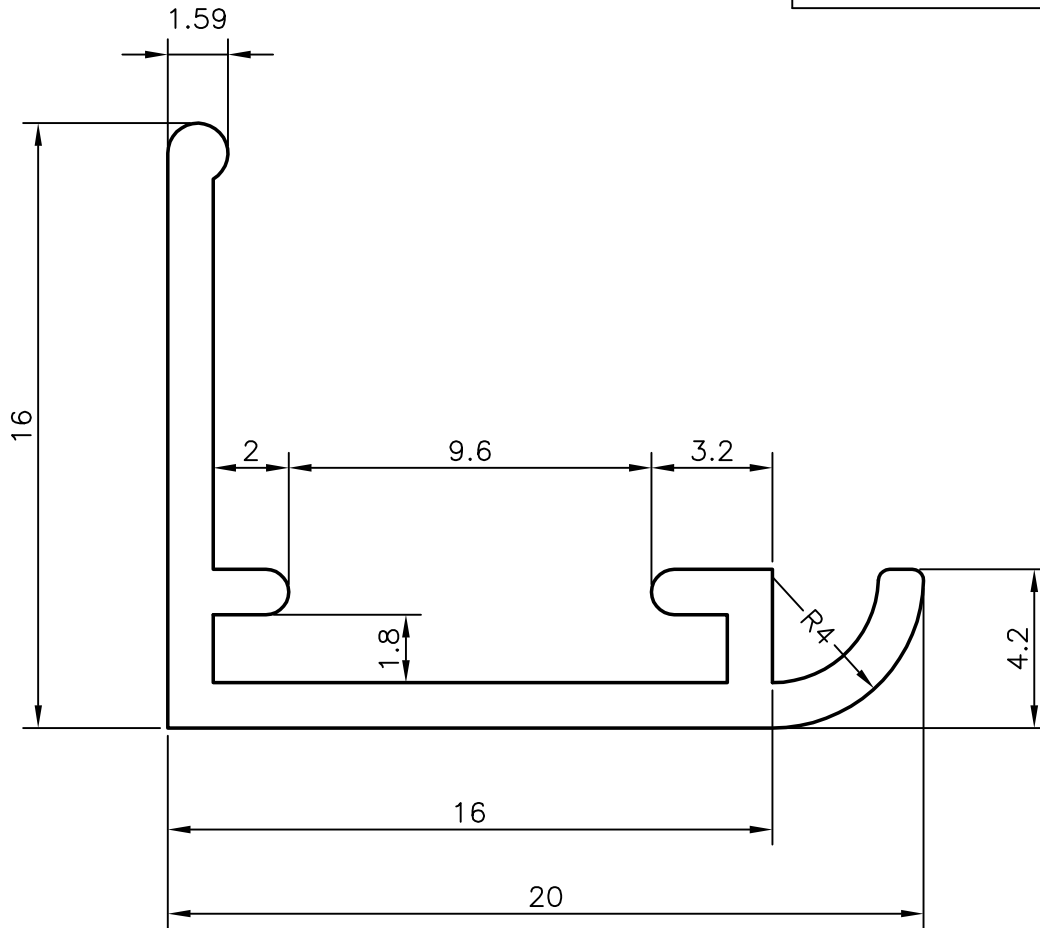
 $+0.30$
 -0.10

GENERAL WALL THICKNESS ;- 1.20 mm.

JINDAL ALUMINIUM LTD.

BANGALORE-560073

NAME

DATE

DRAWN

R.D.Sharma**15.06.99**

1. ALL DIMENSIONS ARE IN mm.
 2. ROUND OFF ALL SHARP CORNERS WITH 0.4 mm.
 3. TOLERANCES WILL BE AS PER IS: 3965-1981 UNLESS OTHERWISE SPECIFIED

CHECKED

APPROVED

PARTY'S NAME

**JAYDEE UTILITY CONSULTANTS PVT. LTD.,
BANGALORE**

SCALE

5:1

PARTY'S DRAWING No.

JUC-FAB-LAM-011-PO

WEIGHT kg/m

0.140

ALLOY & TEMPER

HE9 WP

SECTION No.

26592

LENGTH

3678 mm.

DRAWING No.

DESCRIPTION

GRILL SECTION**26592**