

P-3370-1

7974

26615

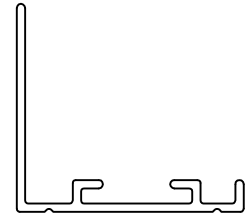

1:1

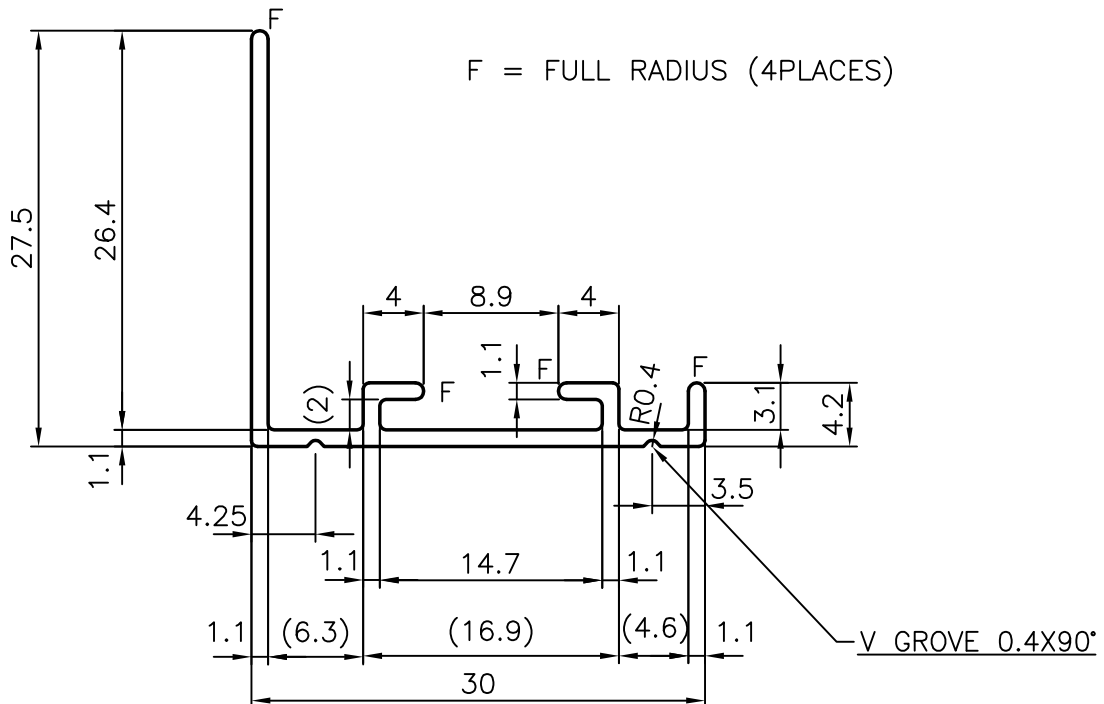

SYMBOL OF QUALITY
AN ISO 9001 COMPANY

JINDAL ALUMINIUM LTD.
BANGALORE-560073 (INDIA)

	NAME	DATE
DRAWN	J.P.KAUSHIK	21-06-2005
CHECKED		
APPROVED		
SCALE	2:1	
AREA mm ²	77.7	
PERIMETER mm.	141.85	
WEIGHT kg/m	0.210	
DRAWING No.	SECTION No.	
P-3370-1		
7974	7974	
26615	26615	

1. ALL DIMENSIONS ARE IN mm.
2. ROUND OFF ALL SHARP CORNERS WITH 0.40 mm.
3. TOLERANCES WILL BE AS PER IS: 3965-1981 UNLESS OTHERWISE SPECIFIED

PARTY'S NAME	DASCO DUCTING & SERVICING CO.,KUWAIT
PARTY'S DRAWING No.	AS PER DRAWING (0054) 12686
ALLOY & TEMPER	HE9 WP
DESCRIPTION	AIR GRILL