

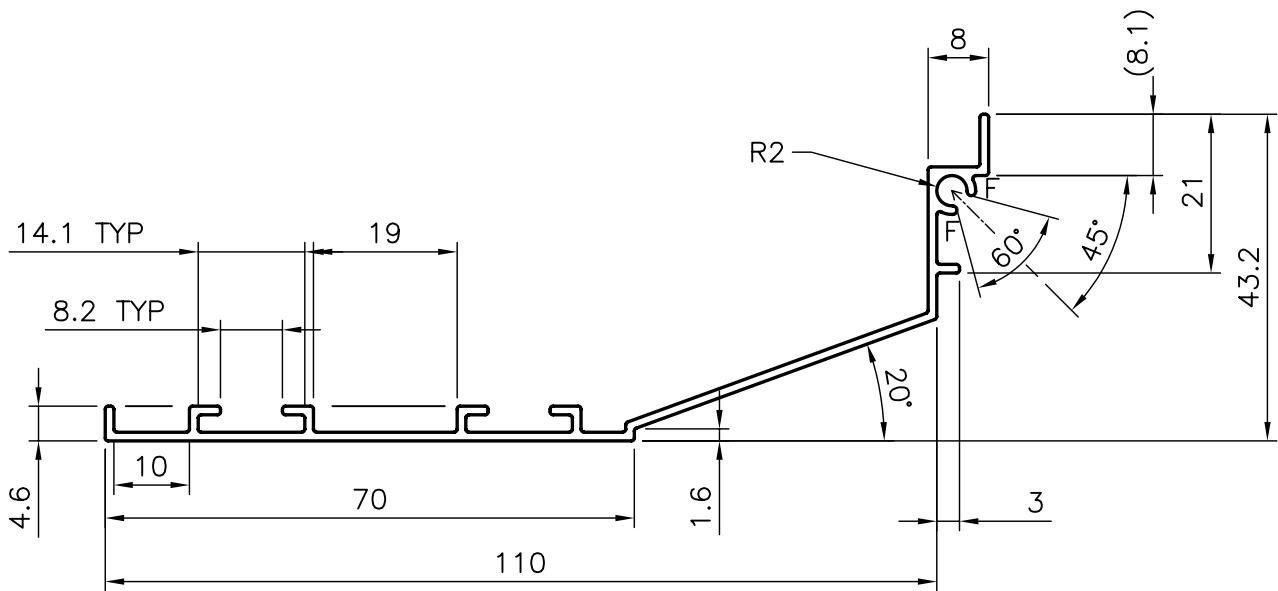

S721  
7983  
26617

Perimeter = 360.855 mm

NOTE:-  
1.FULL RADII (2-PLCS)



GENERAL WALL THICKNESS :- 1.15mm

 SYMBOL OF QUALITY AN ISO 9002 COMPANY	<b>JINDAL ALUMINIUM LTD.</b> BANGALORE-560073 (INDIA)		NAME	DATE
		DRAWN	RANGASWAMY	11-06-01
1. ALL DIMENSIONS ARE IN mm. 2. ROUND OFF ALL SHARP CORNERS WITH 0.40 mm. 3. TOLERANCES WILL BE AS PER I.S 3965-1981 UNLESS OTHERWISE SPECIFIED		CHECKED		
		APPROVED		
PARTY'S NAME		AIR MASTER EQUIPMENTS (I) PVT LTD., BANGALORE	SCALE	1:1
PARTY'S DRAWING No.		AS PER SAMPLE	WEIGHT kg/m	0.571
ALLOY & TEMPER		HE9 WP	SECTION No.	26617
DESCRIPTION		DIFFUSER FRAME	DRAWING No. 26617	