

P-3920

9190

26647

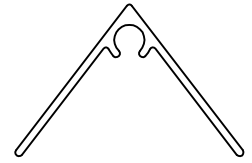

1:1

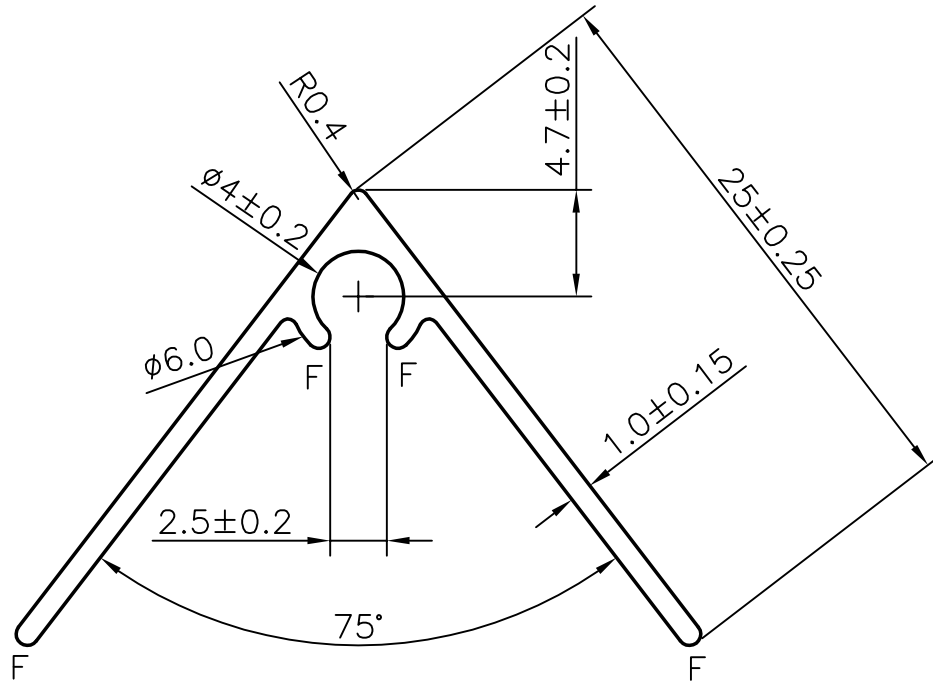

F = FULL RADIUS (4)



SYMBOL OF QUALITY  
AN ISO 9002 COMPANY

**JINDAL ALUMINIUM LTD.**  
BANGALORE-560073 (INDIA)

	NAME	DATE
DRAWN	R.D.Sharma	16-08-02
CHECKED		
APPROVED		

1. ALL DIMENSIONS ARE IN mm.
2. ROUND OFF ALL SHARP CORNERS WITH 0.40 mm.
3. TOLERANCES WILL BE AS PER BS 1474-1987 UNLESS OTHERWISE SPECIFIED

SCALE	3:1
AREA mm <sup>2</sup>	55.6
PERIMETER	104 mm

PARTY'S NAME	AIR MASTER EQUIPMENT, UAE
PARTY'S DRAWING No.	AS PER SKETCH
ALLOY & TEMPER	6063 T6
DESCRIPTION	AIR GRILL SECTION

WEIGHT kg/m	0.150
SECTION No.	26647
DRAWING No.	26647