

S589

9217

26652



SCALE 1:1

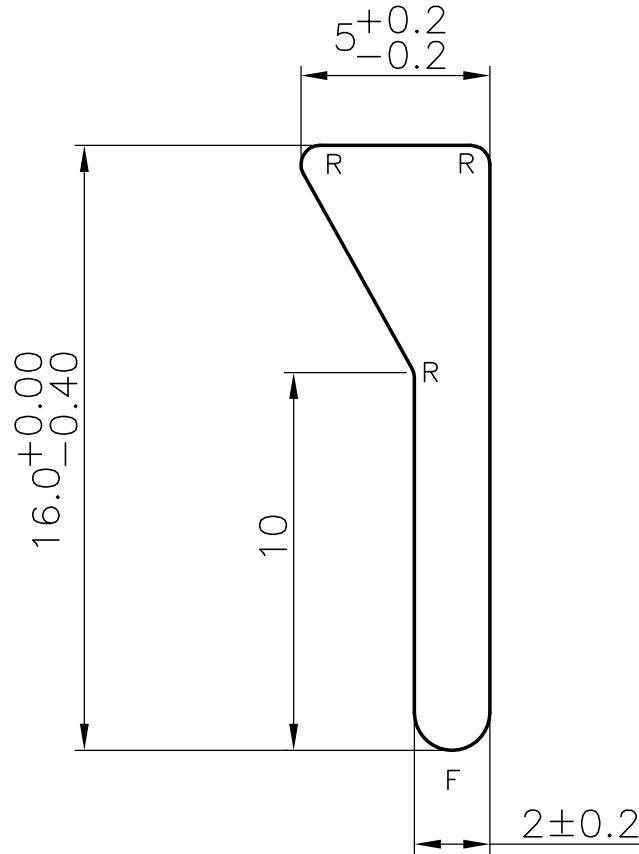

NOTE:

F = FULL RADIUS
R = 0.5 RADIUS



SYMBOL OF QUALITY
AN ISO 9002 COMPANY

JINDAL ALUMINIUM LTD.
BANGALORE-560073 (INDIA)

	NAME	DATE
DRAWN	RANGASWAMY	30-9-2000
CHECKED		
APPROVED		
SCALE	5:1	
WEIGHT kg/m	0.111	
SECTION No.	26652	
DRAWING No.	26652	

1. ALL DIMENSIONS ARE IN mm.
2. ROUND OFF ALL SHARP CORNERS WITH 0.40 mm.
3. TOLERANCES WILL BE AS PER IS: 3965-1981 UNLESS OTHERWISE SPECIFIED

PARTY'S NAME	RAVISTAR INDIA PVT.LTD. UTTAR PARDESH
PARTY'S DRAWING No.	AS PER SAMPLE
ALLOY & TEMPER	6063 T6
DESCRIPTION	AIR GRILL SECTION