

P-4136-1

9255

26666

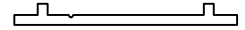

1:1

NO EXPOSED SURFACE

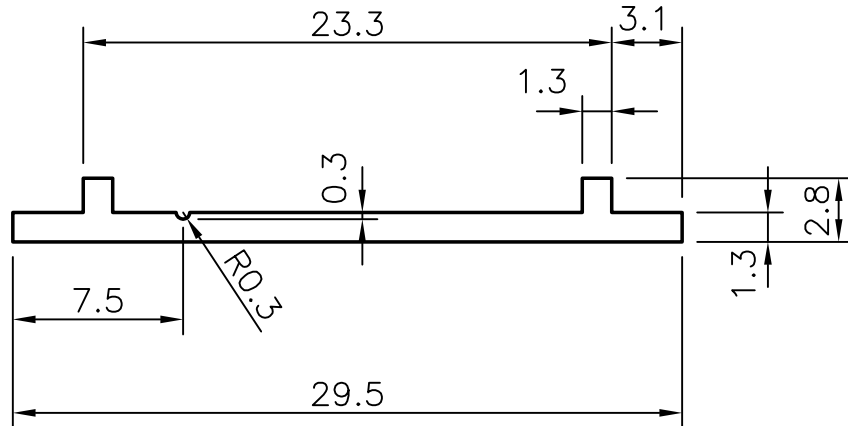

SYMBOL OF QUALITY
AN ISO 9002 COMPANY

JINDAL ALUMINIUM LTD.
BANGALORE-560073 (INDIA)

	NAME	DATE
DRAWN	R.D.Sharma	21-03-03
CHECKED		
APPROVED		

1. ALL DIMENSIONS ARE IN mm.
2. ROUND OFF ALL SHARP CORNERS WITH 0.40 mm.
3. TOLERANCES WILL BE AS PER IS: 3965-1981 UNLESS OTHERWISE SPECIFIED

SCALE	3:1
AREA mm ²	42.1
PERIMETER mm.	67.9

PARTY'S NAME THE CENTRAL INDUSTRIES & AIRCONDITIONING WORKS CO., KUWAIT

PARTY'S DRAWING No. AS PER DRAWING

ALLOY & TEMPER 6063 T6

DESCRIPTION AIR GRILL SECTION

WEIGHT kg/m 0.114

SECTION No. 26666

DRAWING No. 26666