

P-4141-1

9260

26671

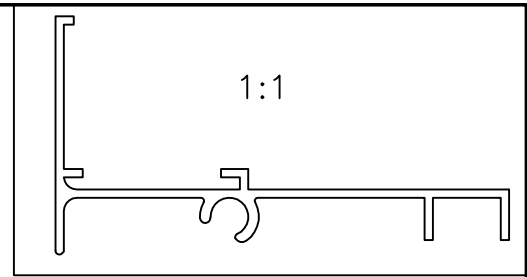

1. GENERAL WALL THICKNESS:- 1.1 mm.
2. F = FULL RADIUS (1)

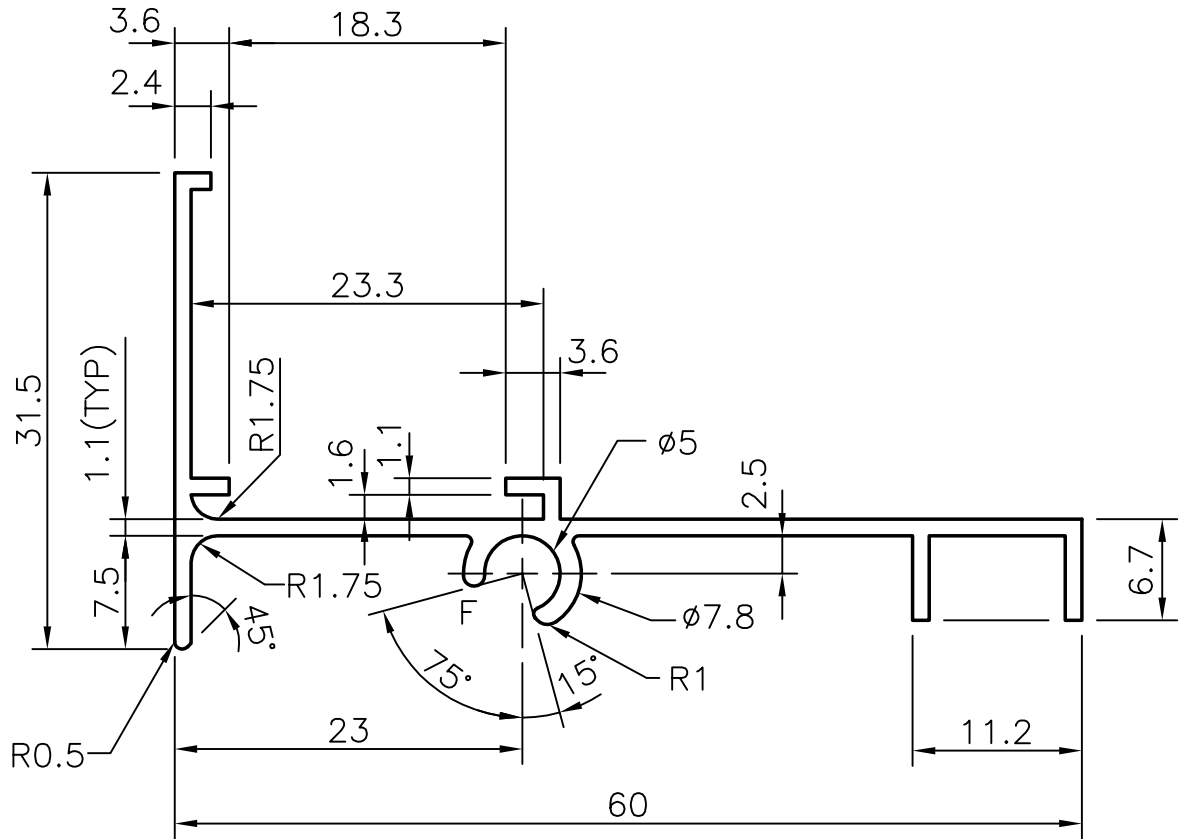

SYMBOL OF QUALITY  
AN ISO 9002 COMPANY

**JINDAL ALUMINIUM LTD.**  
BANGALORE-560073 (INDIA)

	NAME	DATE
DRAWN	R.D.Sharma	21-03-03
CHECKED		
APPROVED		

1. ALL DIMENSIONS ARE IN mm.
2. ROUND OFF ALL SHARP CORNERS WITH 0.40 mm.
3. TOLERANCES WILL BE AS PER IS: 3965-1981 UNLESS OTHERWISE SPECIFIED

SCALE	2:1
AREA mm <sup>2</sup>	137.75
PERIMETER mm.	238.9
WEIGHT kg/m	0.372
SECTION No.	26671
DRAWING No.	26671

PARTY'S NAME	THE CENTRAL INDUSTRIES & AIRCONDITIONING WORKS CO., KUWAIT
PARTY'S DRAWING No.	AS PER DRAWING
ALLOY & TEMPER	6063 T6
DESCRIPTION	AIR GRILL SECTION