

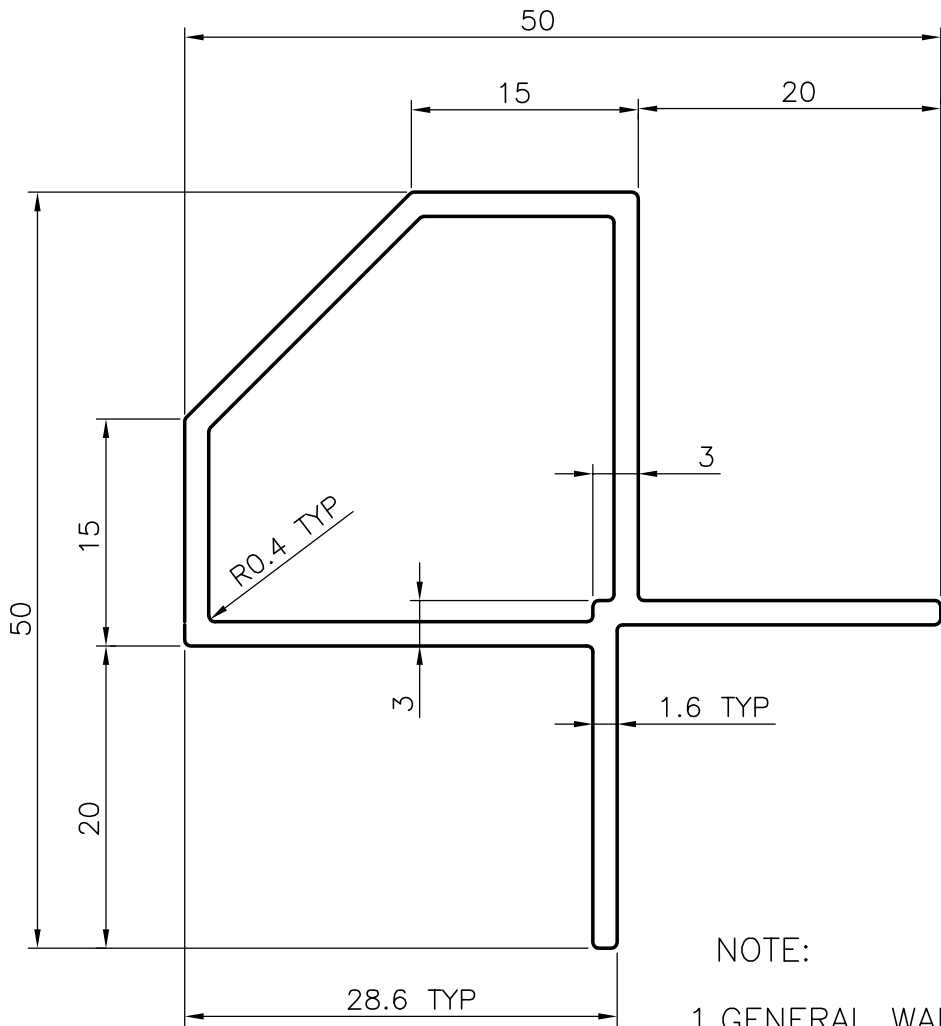

S603
9267
26674

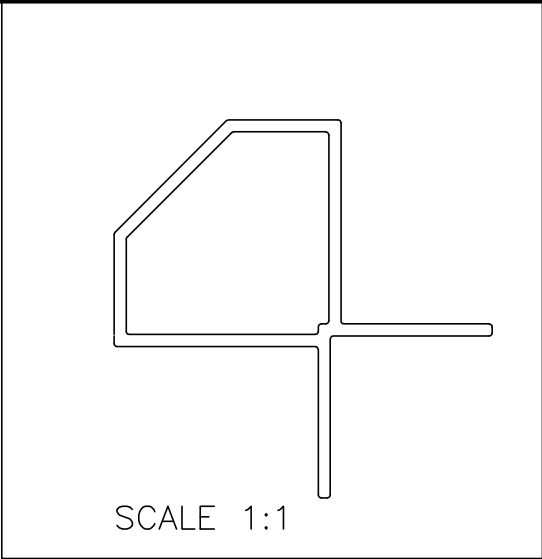

NOTE:  
1. GENERAL WALL THICKNESS 1.6mm.

 SYMBOL OF QUALITY AN ISO 9002 COMPANY	<b>JINDAL ALUMINIUM LTD.</b> BANGALORE-560073 (INDIA)		NAME	DATE
		DRAWN	RANGASWAMY	13-12-2K
1. ALL DIMENSIONS ARE IN mm. 2. ROUND OFF ALL SHARP CORNERS WITH 0.40 mm. 3. TOLERANCES WILL BE AS PER I.S. 6477-1983 UNLESS OTHERWISE SPECIFIED		CHECKED		
		APPROVED		
PARTY'S NAME	PATELS AIRTEMP (I) LTD., MEHSANA	SCALE	2:1 & 1:1	
PARTY'S DRAWING No.	AS PER DRAWING (TYPE Y)	WEIGHT kg/m	0.626	
ALLOY & TEMPER	HE9 WP	SECTION No.	26674	
DESCRIPTION	MISC. HOLLOW	DRAWING No.	26674	