

P-4226

S1017

26684

1. GENERAL WALL THICKNESS:- 1.20 mm.
2. F = FULL RADIUS (2)

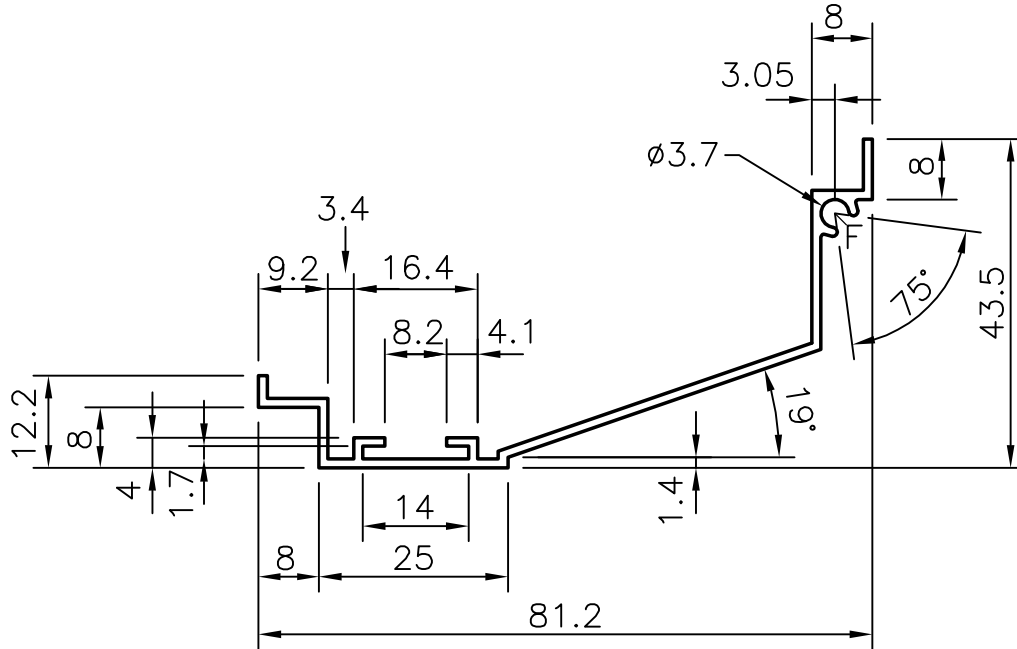

SYMBOL OF QUALITY  
AN ISO 9002 COMPANY

**JINDAL ALUMINIUM LTD.**  
BANGALORE-560073 (INDIA)

	NAME	DATE
DRAWN	R.D.Sharma	07-05-2003
CHECKED		
APPROVED		

1. ALL DIMENSIONS ARE IN mm.
2. ROUND OFF ALL SHARP CORNERS WITH 0.40 mm.
3. TOLERANCES WILL BE AS PER IS 3965-1981 UNLESS OTHERWISE SPECIFIED

SCALE	1:1
AREA mm <sup>2</sup>	166.9
PERIMETER mm.	276
WEIGHT kg/m	0.451

PARTY'S NAME	AIR MASTER EQPT. (I) PVT. LTD, BANGALORE
PARTY'S DRAWING No.	AS PER SAMPLE
ALLOY & TEMPER	HE9 WP
DESCRIPTION	AIR GRILL SECTION

DRAWING No.	SECTION No.
P-4226	-
S1017	S1017
26684	26684