

P-4214

S1185

26685

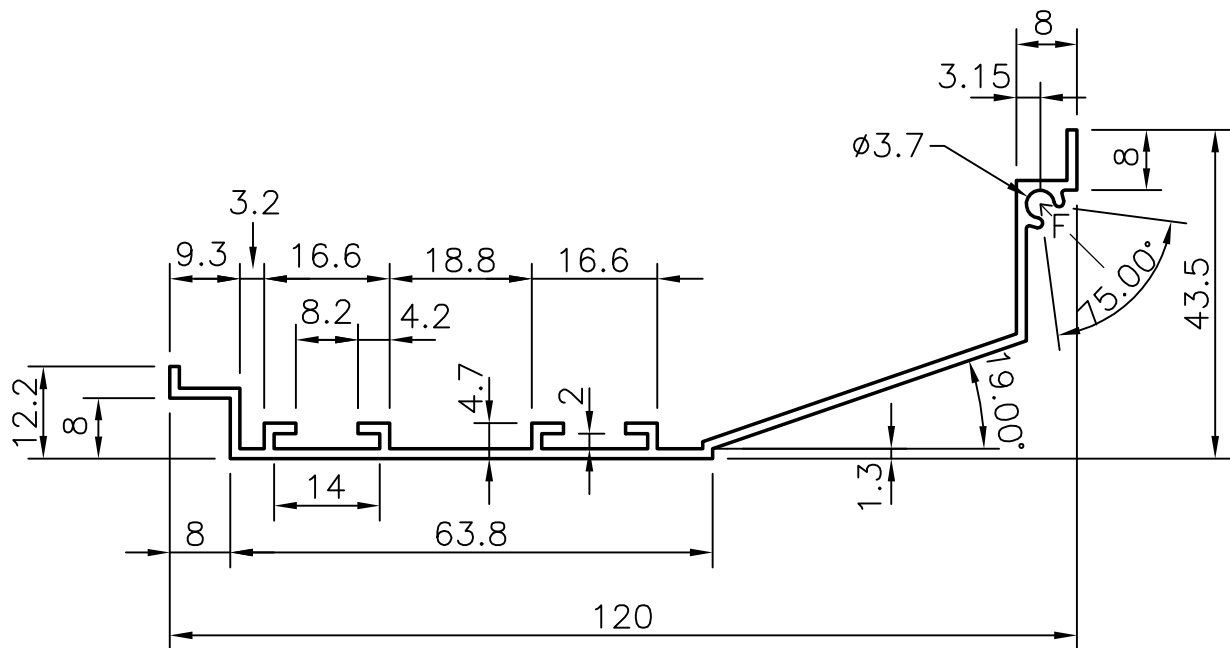

1. GENERAL WALL THICKNESS:- 1.30 mm.
2. F = FULL RADIUS (2)



SYMBOL OF QUALITY
AN ISO 9002 COMPANY

JINDAL ALUMINIUM LTD.
BANGALORE-560073 (INDIA)

	NAME	DATE
DRAWN	R.D.Sharma	28-04-03
CHECKED		
APPROVED		
SCALE		1:1
AREA mm ²		250.45
PERIMETER mm.		381
WEIGHT kg/m		0.676
DRAWING No.	SECTION No.	
P-4214	-	
S1185	S1185	
26685	26685	

1. ALL DIMENSIONS ARE IN mm.
2. ROUND OFF ALL SHARP CORNERS WITH 0.40 mm.
3. TOLERANCES WILL BE AS PER IS:3965-1981 UNLESS OTHERWISE SPECIFIED

PARTY'S NAME	AIR MASTER EQPT. (I) PVT. LTD, BANGALORE
PARTY'S DRAWING No.	AS PER SAMPLE
ALLOY & TEMPER	HE9 WP
DESCRIPTION	AIR GRILL SECTION