

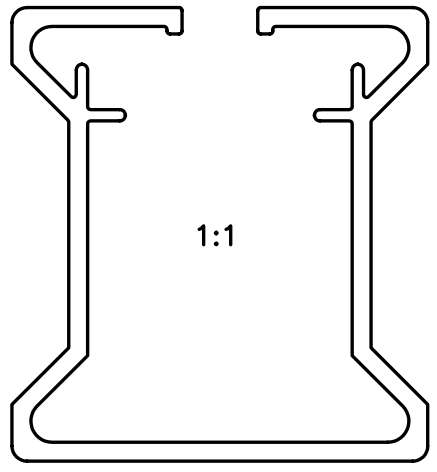

P-2809
S532
X227
7077
X227
26695

F = RADII FULL (4-PLACES)
R = RADII 2.00 (4-PLACES)

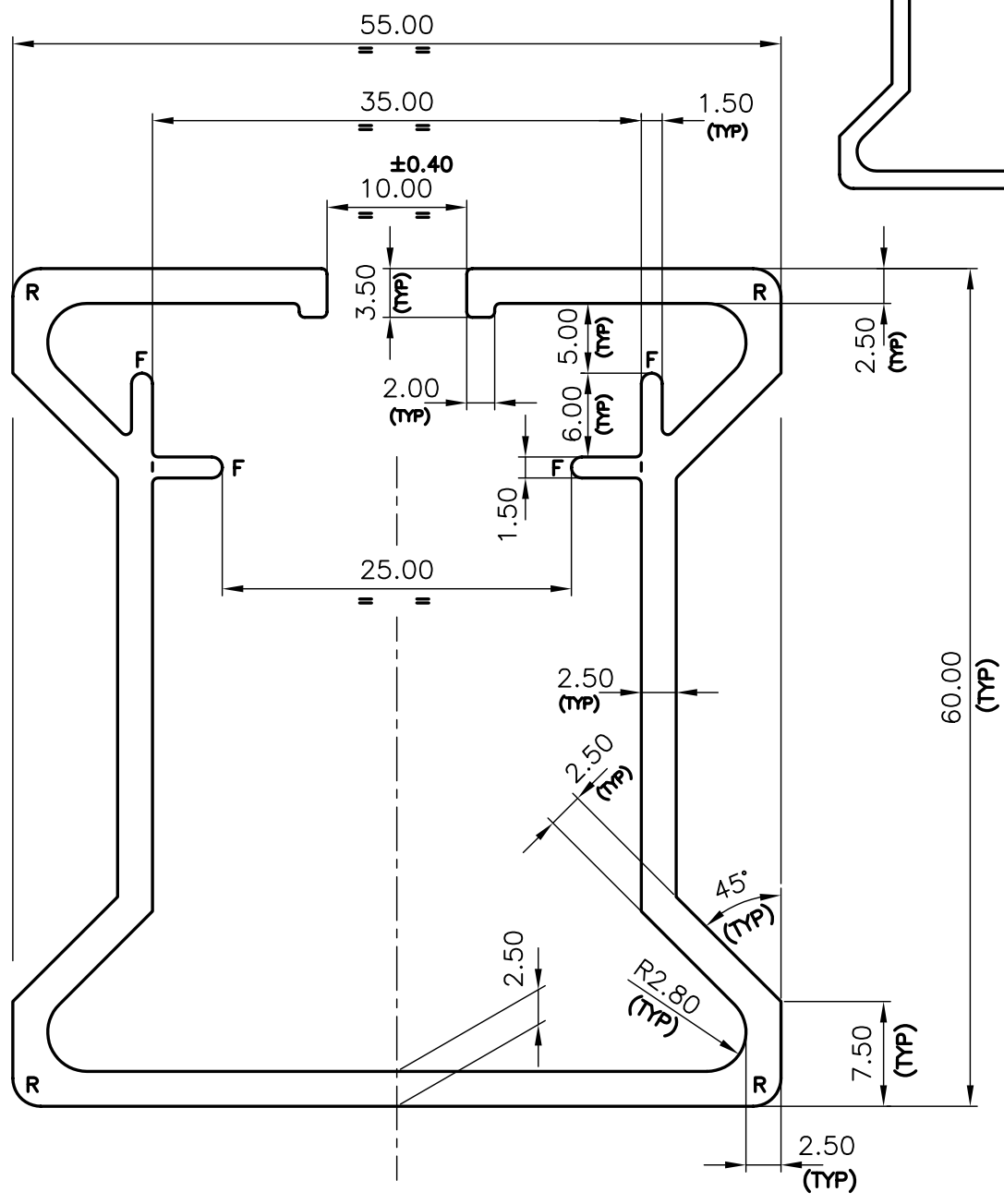

1:1



 SYMBOL OF QUALITY AN ISO 9002 COMPANY	JINDAL ALUMINIUM LTD. BANGALORE-560073 (INDIA)	NAME	DATE
		DRAWN	P,KULKARNI 1-6-2000
1. ALL DIMENSIONS ARE IN mm. 2. ROUND OFF ALL SHARP CORNERS WITH 0.40 mm. 3. TOLERANCES WILL BE AS PER I.S. 3965-1981 UNLESS OTHERWISE SPECIFIED		CHECKED	
		APPROVED	
		SCALE	2:1
PARTY'S NAME		WEIGHT kg/m	1.608
PARTY'S DRAWING No.	AS PER SKETCH	SECTION No.	26695
ALLOY & TEMPER	HE9 WP	DRAWING No.	
DESCRIPTION	AIR GRILL SECTION	26695	