

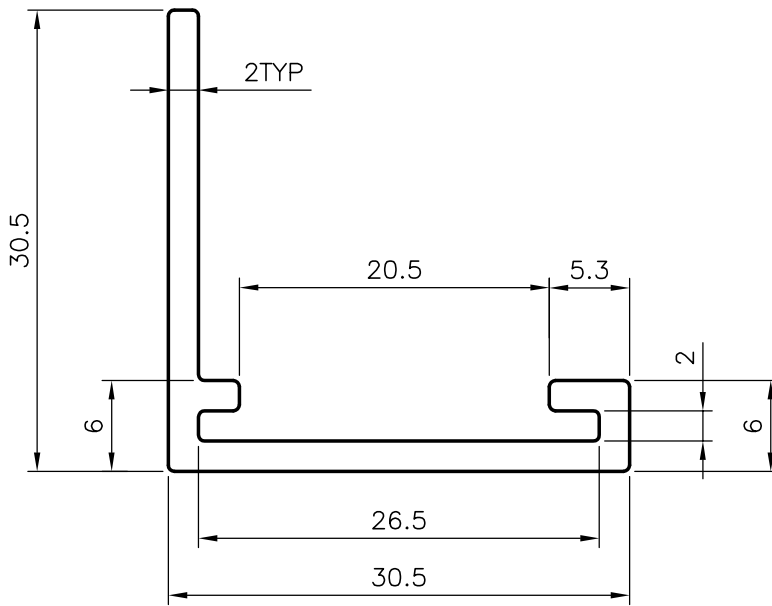

P-3528-1
S782
X231
7080
X231
26699

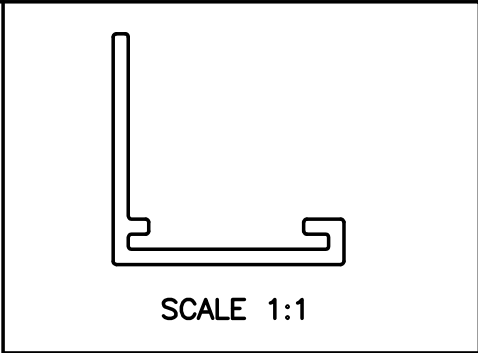

GENERAL WALL THICKNESS = 2mm

 SYMBOL OF QUALITY AN ISO 9002 COMPANY	JINDAL ALUMINIUM LTD. BANGALORE-560073 (INDIA)		NAME	DATE
		DRAWN	RAGHAVENDRA	20-09-01
1. ALL DIMENSIONS ARE IN mm. 2. ROUND OFF ALL SHARP CORNERS WITH 0.40 mm. 3. TOLERANCES WILL BE AS PER IS: 3965-1981 UNLESS OTHERWISE SPECIFIED		CHECKED		
		APPROVED		
PARTY'S NAME		ZECO AIRCON INDUSTRIES PVT. LTD. DELHI	SCALE	2:1 & 1:1
PARTY'S DRAWING No.		AS PER DRAWING	WEIGHT kg/m	0.372
ALLOY & TEMPER		HE9 WP	PERIMETER	139.60mm
DESCRIPTION		-	SECTION No.	26699
			DRAWING No.	26699