

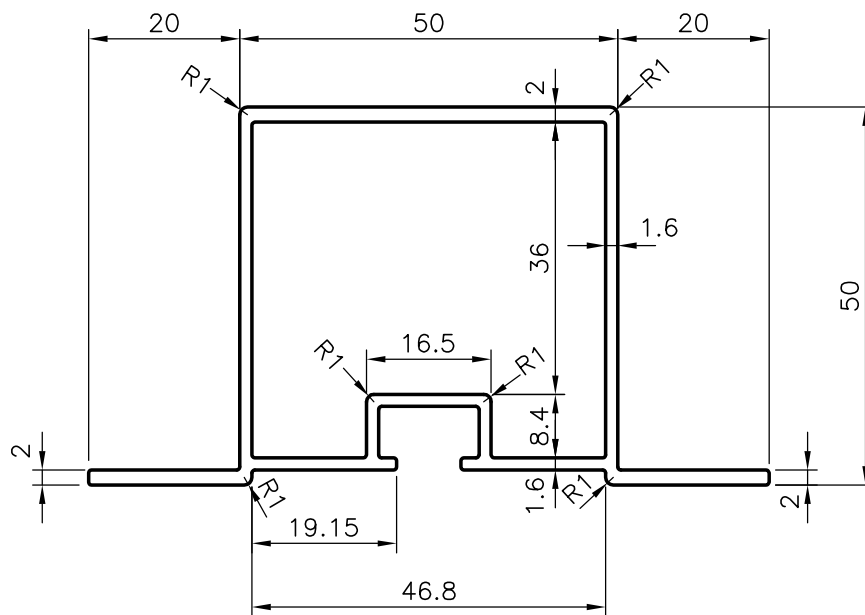

P-5141-1
S1435
26707



1. UNSPECIFIED WALL THICKNESS:- 1.60 mm.

 SYMBOL OF QUALITY AN ISO 9001 COMPANY	JINDAL ALUMINIUM LTD. BANGALORE-560073 (INDIA)	NAME		DATE
		DRAWN	RAGHAVENDRA	18-11-2004
1. ALL DIMENSIONS ARE IN mm. 2. ROUND OFF ALL SHARP CORNERS WITH 0.40 mm. 3. TOLERANCES WILL BE AS PER IS:6477-1983 UNLESS OTHERWISE SPECIFIED		CHECKED		
		APPROVED		
PARTY'S NAME TRAC FUJICO AIR SYSTEMS LTD., PONDICHERRY		SCALE		1:1
		AREA mm ²		441.958
PARTY'S DRAWING No. AS PER DRAWING		PERIMETER mm.		305.936
		WEIGHT kg/m		1.193
ALLOY & TEMPER HE9 WP		DRAWING No.	SECTION No.	
		P-5141-1	-	
DESCRIPTION AIR CONDITIONER SECTION		S1435	S1435	
		26707	26707	