

P-5142

S1436

26708

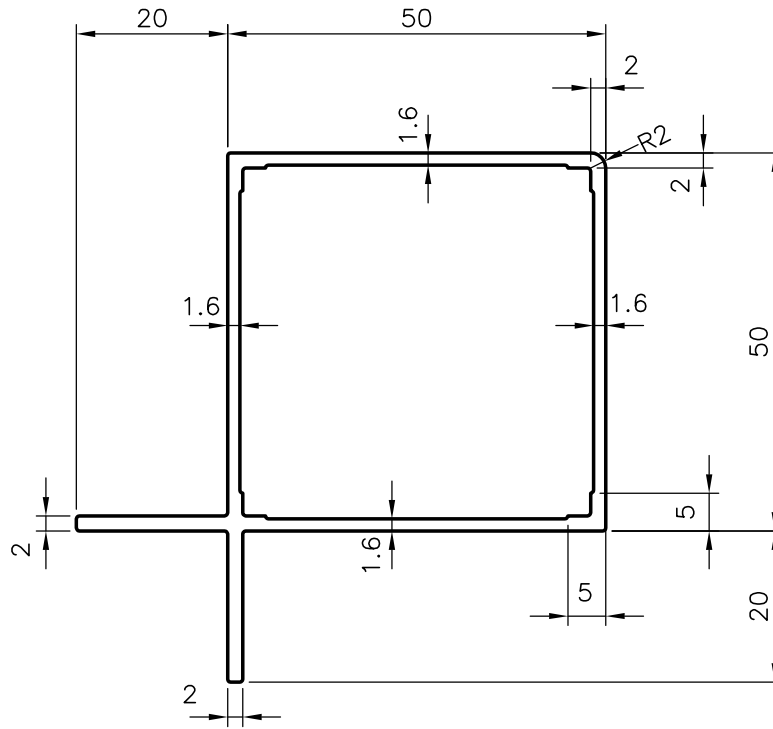

SYMBOL OF QUALITY
AN ISO 9001 COMPANY

JINDAL ALUMINIUM LTD.
BANGALORE-560073 (INDIA)

	NAME	DATE
DRAWN	malingappa	13-11-2004
CHECKED		
APPROVED		

1. ALL DIMENSIONS ARE IN mm.
2. ROUND OFF ALL SHARP CORNERS WITH 0.40 mm.
3. TOLERANCES WILL BE AS PER IS:6477-1983 UNLESS OTHERWISE SPECIFIED

SCALE	1:1
AREA mm ²	399.45
PERIMETER mm.	277.6
WEIGHT kg/m	1.079

PARTY'S NAME	TRAC FUJICO AIR SYSTEMS LTD., PONDICHERRY
PARTY'S DRAWING No.	AS PER DRAWING
ALLOY & TEMPER	HE9 WP
DESCRIPTION	AIR CONDITIONER SECTION

DRAWING No.	SECTION No.
P-5142	-
S1436	S1436
26708	26708