

P-5535

X404

26732

STRAIGHTNESS 1.00 mm/METER $+0.20$
 GENERAL WALL THICKNESS = 0.95mm -0.10
 R = RADII 0.25 (8 PLACES)
 F = FULL RADIUS (1 PLACE)

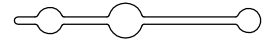

SCALE 1:1

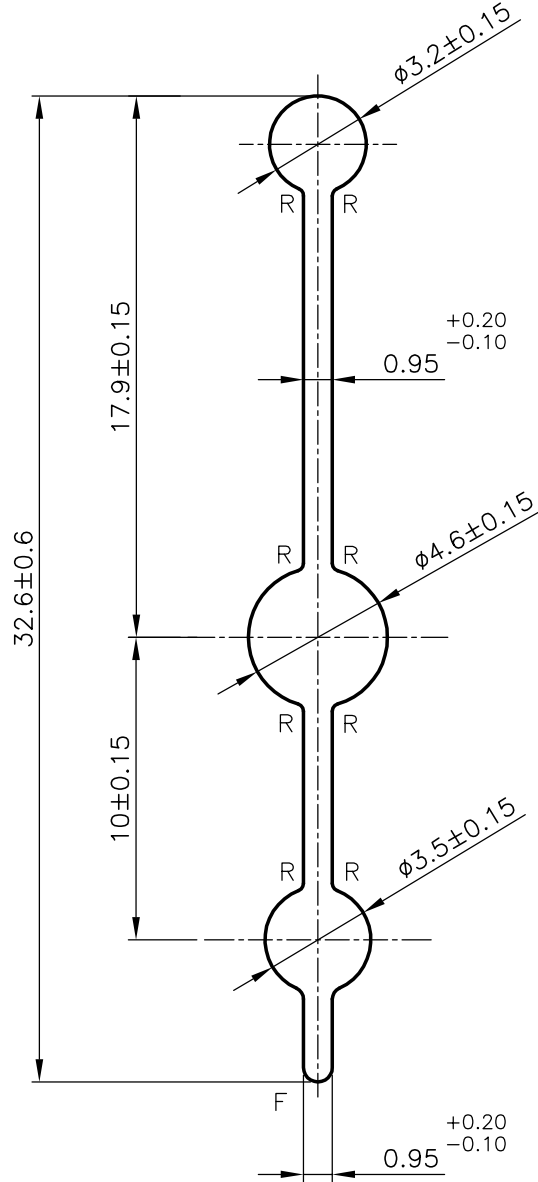

SYMBOL OF QUALITY
AN ISO 9001 COMPANY

JINDAL ALUMINIUM LTD.
BANGALORE-560073 (INDIA)

	NAME	DATE
DRAWN	RAGHAVENDRA	30-05-2005
CHECKED		
APPROVED		
SCALE		4:1
AREA mm ²		54.593
PERIMETER mm.		73.885
WEIGHT kg/m		0.147
DRAWING No.	SECTION No.	
P-5535	-	
X404	X404	
26732	26732	

1. ALL DIMENSIONS ARE IN mm.
2. ROUND OFF ALL SHARP CORNERS WITH 0.40 mm.
3. TOLERANCES WILL BE AS PER IS:3965-1981 UNLESS OTHERWISE SPECIFIED

PARTY'S NAME	RAVISTAR INDIA PVT LTD, UTTAR PRADESH
PARTY'S DRAWING No.	LIGHTER OF SECTION NO. X112
ALLOY & TEMPER	6063 T6
DESCRIPTION	DAMPER BLADE