

P-6530-1

X592

26760

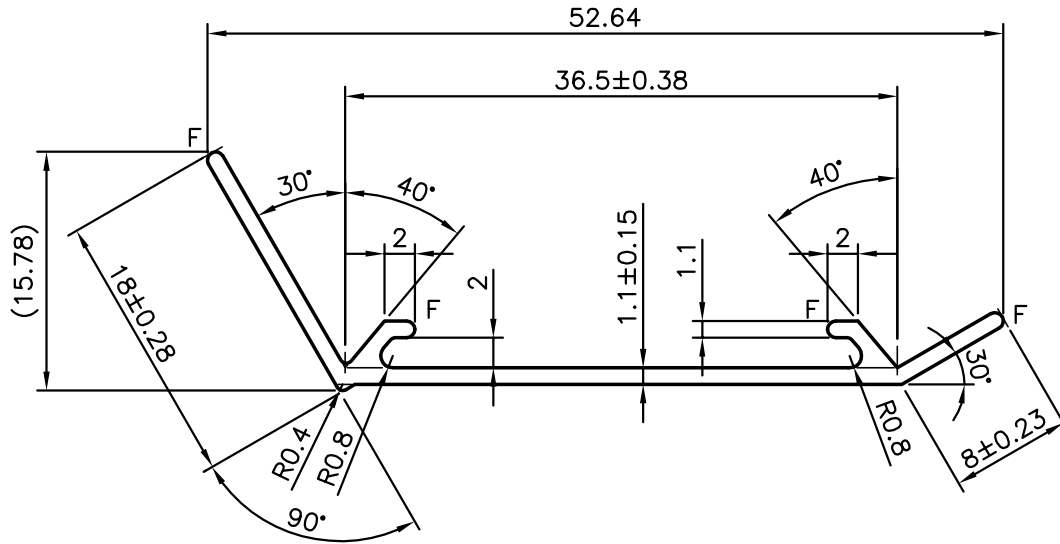
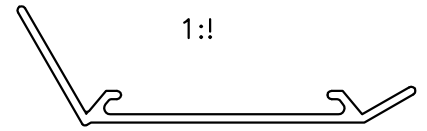

1. GENERAL WALL THICKNESS:-  $1.10 \pm 0.15$  mm.
2. F = FULL RADIUS (4)



SYMBOL OF QUALITY  
AN ISO 9001 COMPANY

**JINDAL ALUMINIUM LTD.**  
BANGALORE-560073 (INDIA)

	NAME	DATE
DRAWN	malingappa	30-06-2006
CHECKED		
APPROVED		

1. ALL DIMENSIONS ARE IN mm.
2. ROUND OFF ALL SHARP CORNERS WITH 0.40 mm.
3. TOLERANCES WILL BE AS PER IS:3965-1981 UNLESS OTHERWISE SPECIFIED

SCALE	2:1
AREA mm <sup>2</sup>	80.379
PERIMETER mm.	140.294
WEIGHT kg/m	0.217

PARTY'S NAME	AIR MASTER EQPT. (I) PVT. LTD., BANGALORE
PARTY'S DRAWING No.	AS PER DRAWING (26553-MODIFIED)
ALLOY & TEMPER	HE9 WP
DESCRIPTION	AIR GRILL SECTION

DRAWING No.	SECTION No.
P-6530-1	-
X592	X592
26760	26760