

P-7230

26779

DETAIL OF "A"
SCALE 3:1

SCALE 1:1

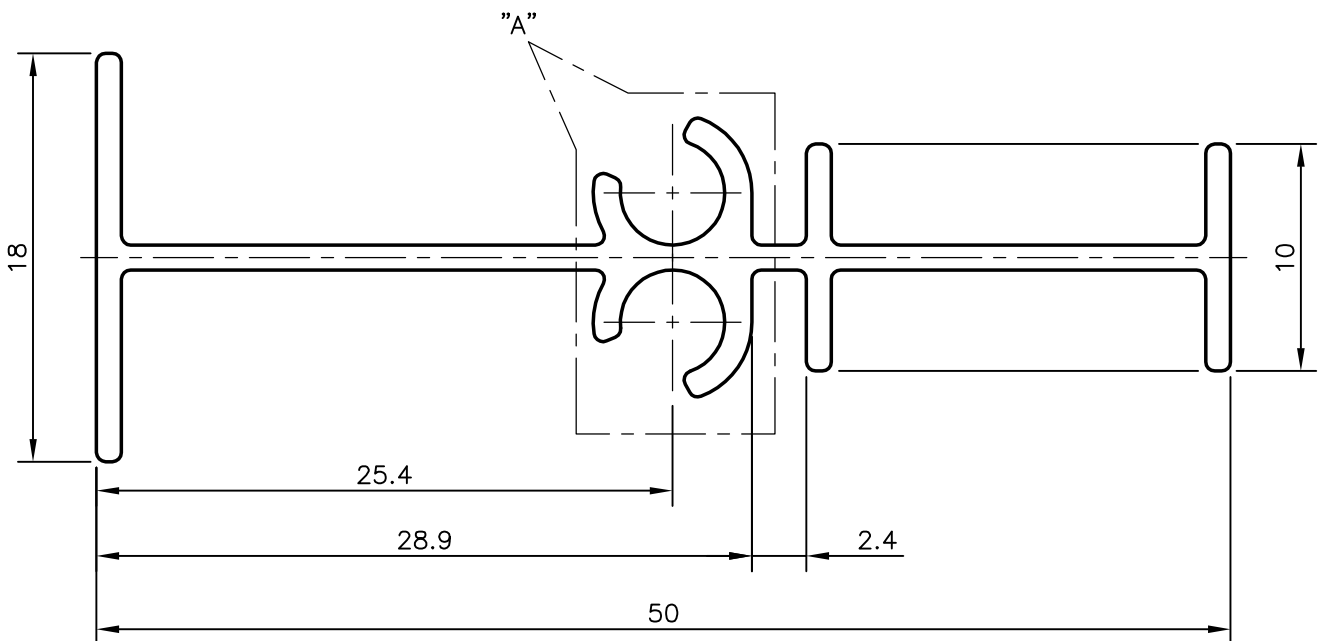
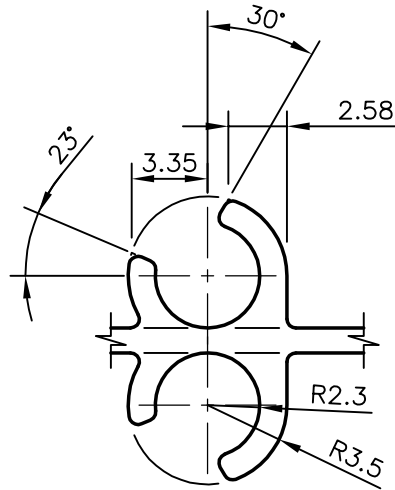
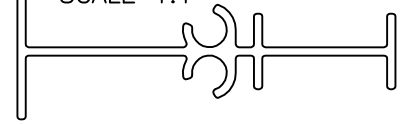

NOTE:-

1. GENERAL WALL THICKNESS = 1.10 mm



SYMBOL OF QUALITY
AN ISO 9001 COMPANY

JINDAL ALUMINIUM LTD.
BANGALORE-560073 (INDIA)

	NAME	DATE
DRAWN	PRASANN.H	24-04-2007
CHECKED		
APPROVED		

1. ALL DIMENSIONS ARE IN mm.
2. ROUND OFF ALL SHARP CORNERS WITH 0.40 mm.
3. TOLERANCES WILL BE AS PER BS:EN-755 UNLESS OTHERWISE SPECIFIED

SCALE	3:1
AREA mm ²	118.724
PERIMETER mm.	200.595
WEIGHT kg/m	0.321

PARTY'S NAME	ALDES MIDDLE EAST (FZE), U.A.E.
PARTY'S DRAWING No.	AL-PRD-GRL-179
ALLOY & TEMPER	6063 T6
DESCRIPTION	AIR GRILL-SLOT DIFFUSER INNER SECTION

DRAWING No.	SECTION No.
P-7230	-
26779	26779