

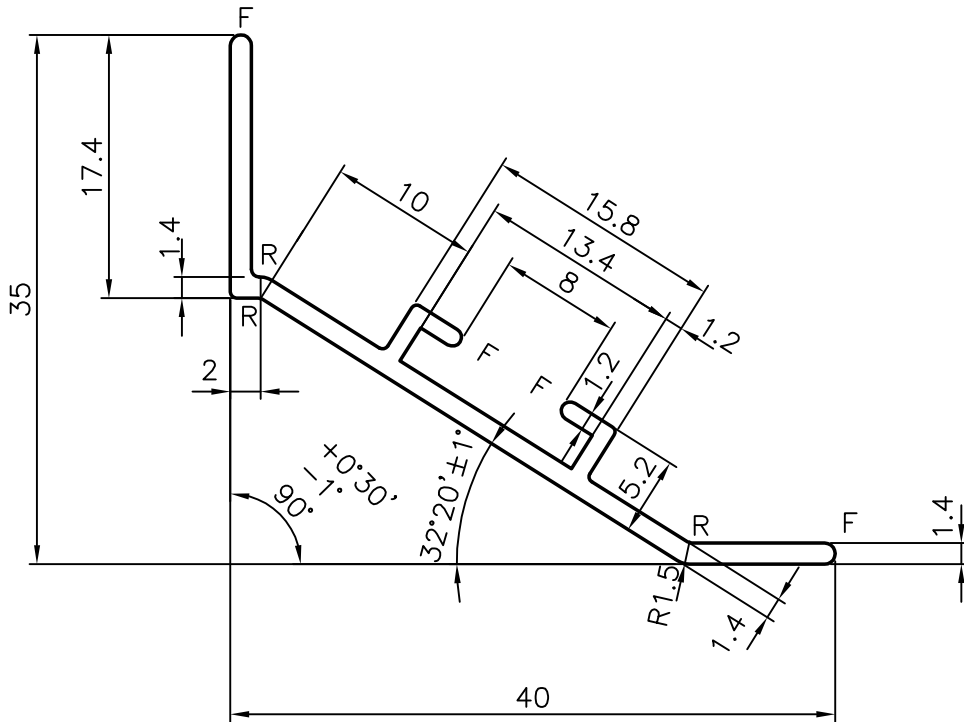

P-5866-3
X633
26783

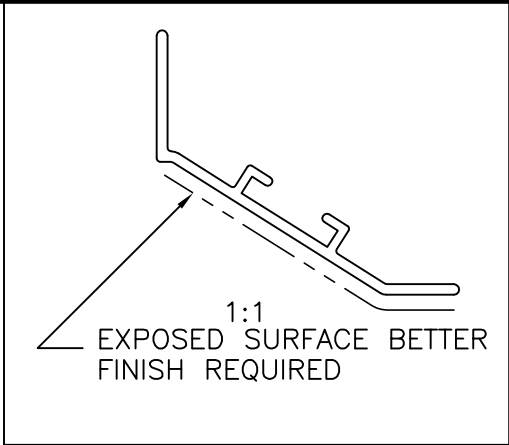
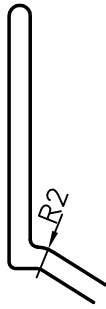

GENERAL WALL THICKNESS 1.40 mm
 F = FULL RADIUS (4)
 R = 0.5 RADIUS (3)

 SYMBOL OF QUALITY AN ISO 9001 COMPANY	JINDAL ALUMINIUM LTD. BANGALORE-560073 (INDIA)	DRAWN	NAME	DATE
		CHECKED	RAGHAVENDRA	17-10-2006
1. ALL DIMENSIONS ARE IN mm. 2. ROUND OFF ALL SHARP CORNERS WITH 0.40 mm. 3. TOLERANCES WILL BE AS PER DIN-1748 UNLESS OTHERWISE SPECIFIED		APPROVED		
		SCALE	2:1	
PARTY'S NAME TECHNOTRADE LTD., RUSSIA		AREA mm ²	100.45	
		PERIMETER mm.	147.046	
PARTY'S DRAWING No. AS PER DRAWING		WEIGHT kg/m	0.271	
		DRAWING No.	SECTION No.	
ALLOY & TEMPER 6060 T1		P-5866-3	-	
		X633	X633	
DESCRIPTION AIR GRILL		26783	26783	