

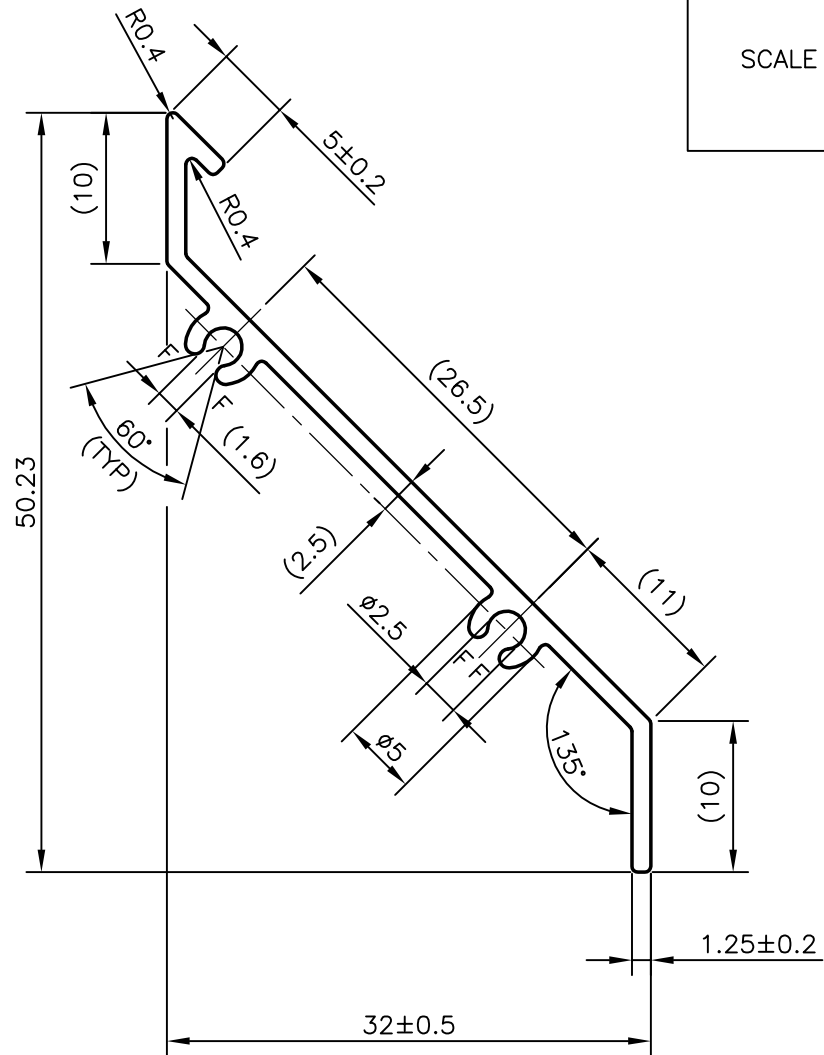

P-7546

26786

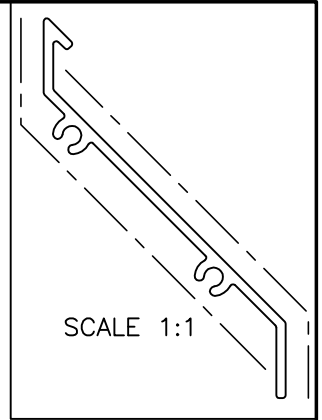

NOTE:--

1. F = FULL RADIUS (4 PLACE)
2. GENERAL WALL THICKNESS = 1.25 ± 0.2
3. — — — — EXPOSED SUEFACE

 SYMBOL OF QUALITY AN ISO 9001 COMPANY	JINDAL ALUMINIUM LTD. BANGALORE-560073 (INDIA)	NAME		DATE
		DRAWN	PRASANN.H	09-10-2007
1. ALL DIMENSIONS ARE IN mm. 2. ROUND OFF ALL SHARP CORNERS WITH 0.40 mm. 3. TOLERANCES WILL BE AS PER BS:EN-755 UNLESS OTHERWISE SPECIFIED		CHECKED		
		APPROVED		
PARTY'S NAME EASA HUSSAIN AL-YOUSIFI & SONS CO, KUWAIT		SCALE		2:1
		AREA mm ²		99.85
PARTY'S DRAWING No. AS PER DRAWING		PERIMETER mm.		152.554
		WEIGHT kg/m		0.270
ALLOY & TEMPER 6063 T6		DRAWING No.		SECTION No.
		P-7546		-
DESCRIPTION AIR GRILL SECTION-FAL BLADE		26786		26786