

P-7734-2

26798

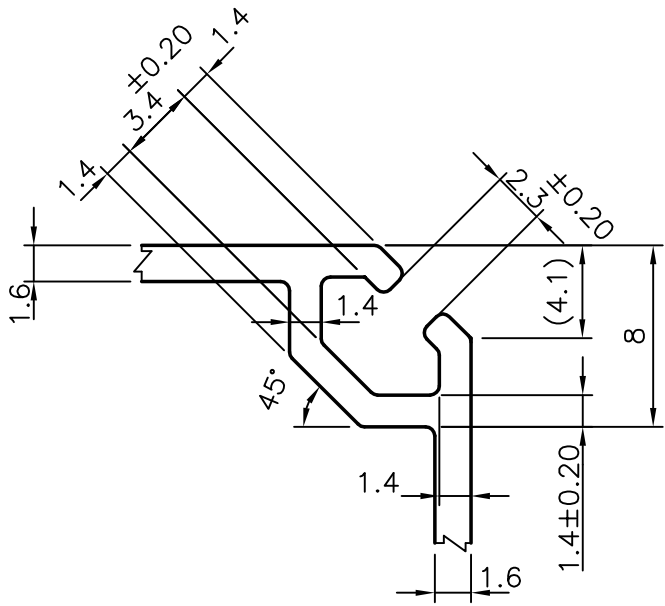

**DETAIL-A**

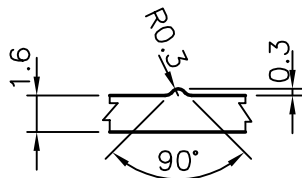
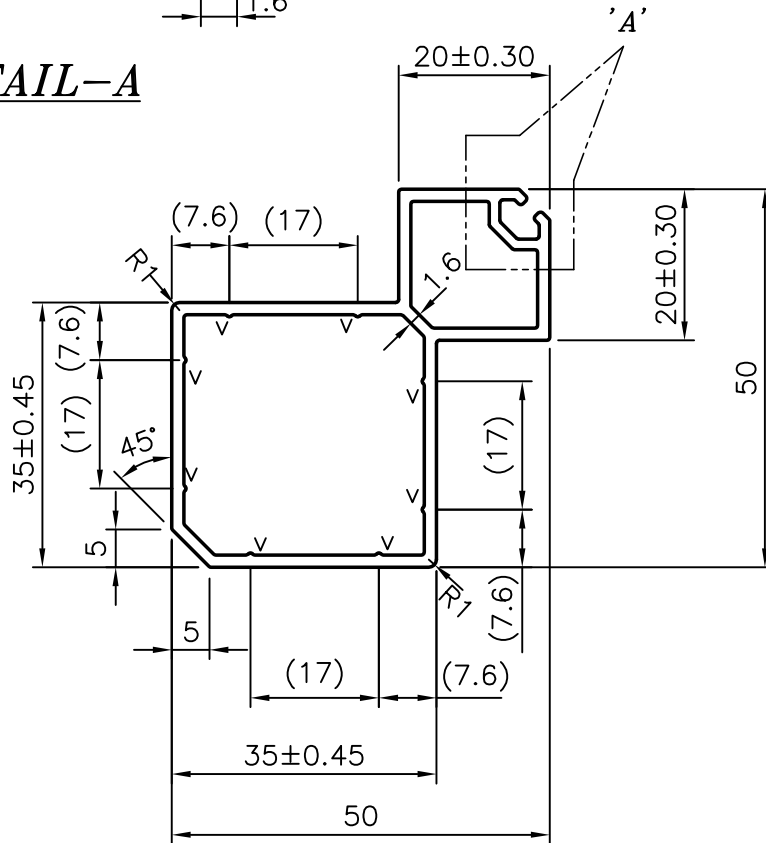

**'V'-GROOVE DETAIL**

GENERAL WALL THICKNESS 1.6±0.20 mm(TYP)

 SYMBOL OF QUALITY AN ISO 9001 COMPANY	<b>JINDAL ALUMINIUM LTD.</b> BANGALORE-560073 (INDIA)	NAME	DATE
		DRAWN	J.P.KAUSHIK 19-01-2008
		CHECKED	
1. ALL DIMENSIONS ARE IN mm. 2. ROUND OFF ALL SHARP CORNERS WITH 0.40 mm. 3. TOLERANCES WILL BE AS PER IS:6477-1983 UNLESS OTHERWISE SPECIFIED		APPROVED	
PARTY'S NAME	CLIVET TF AIR SYSTEMS (P) LTD.,KOLAR	SCALE	1:1
PARTY'S DRAWING No.	AS PER DRAWING	AREA mm <sup>2</sup>	317.367
ALLOY & TEMPER	HE9 WP	PERIMETER mm.	207.698
DESCRIPTION	AIR GRILL SECTION	WEIGHT kg/m	0.857
		DRAWING No.	SECTION No.
		P-7734-2	-
		26798	26798