

P-7098

S1984

26803

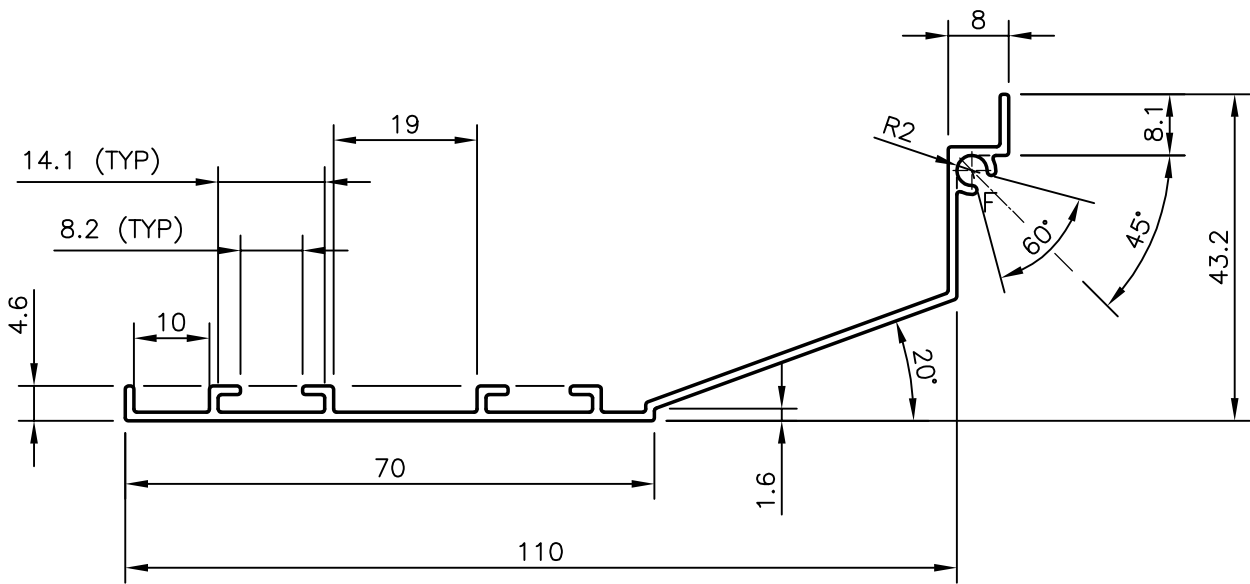

NOTE:-

1. GENERAL WALL THICKNESS = 1.15 ± 0.15 mm
2. F = FULL RADIUS (2 PLACES)



SYMBOL OF QUALITY
AN ISO 9001 COMPANY

JINDAL ALUMINIUM LTD.
BANGALORE-560073 (INDIA)

	NAME	DATE
DRAWN	PRASANN.H	07-03-2007
CHECKED		
APPROVED		

1. ALL DIMENSIONS ARE IN mm.
2. ROUND OFF ALL SHARP CORNERS WITH 0.40 mm.
3. TOLERANCES WILL BE AS PER IS:3965-1981 UNLESS OTHERWISE SPECIFIED

SCALE	1:1
AREA mm ²	209.93
PERIMETER mm.	355.575
WEIGHT kg/m	0.567

PARTY'S NAME AIRGUIDE & CONTROL, BANGALORE

PARTY'S DRAWING No. AS PER DRAWING

ALLOY & TEMPER HE9 WP

DESCRIPTION AIR GRILL SECTION-DIFFUSER FRAME

DRAWING No.	SECTION No.
P-7098	-
S1984	S1984
26803	26803