

P-8383-2

26809

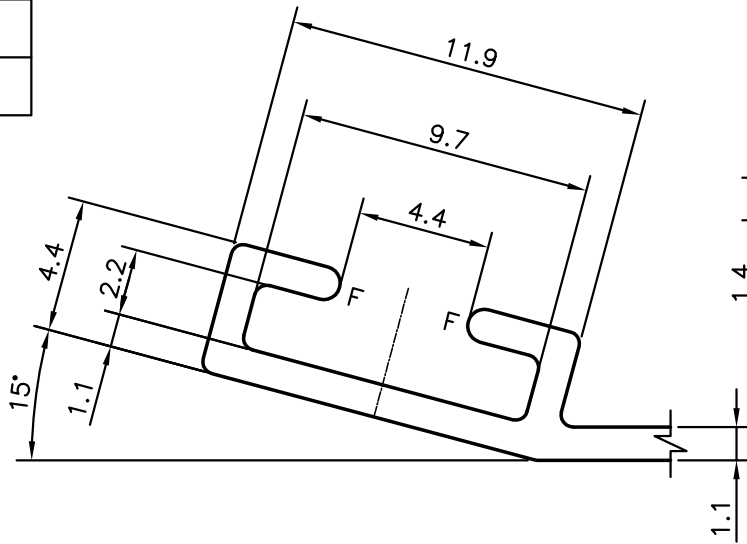

DETAIL OF "A"
SCALE 4:1

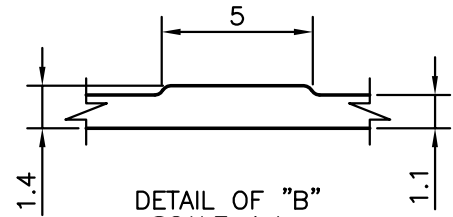

DETAIL OF "B"
SCALE 4:1

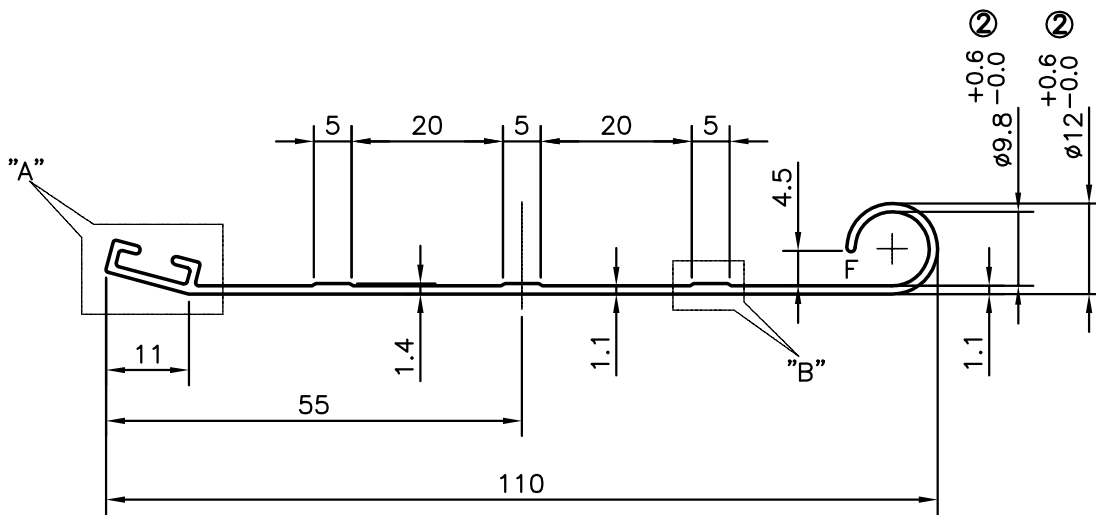

ISSUE (2) :-

F = FULL RADIUS (3 PLACES)

TOLERANCE $\begin{matrix} +0.6 \\ -0.0 \end{matrix}$ ADDED
ON DIMENSIONS :-

1. $\phi 9.8$
2. $\phi 12.0$



SYMBOL OF QUALITY
AN ISO 9001 COMPANY

JINDAL ALUMINIUM LTD.
BANGALORE-560073 (INDIA)

	NAME	DATE
DRAWN	PARVESH	04-12-2012
CHECKED		
APPROVED	B.NATARAJA	10-12-2012
SCALE		1:1
AREA	mm ²	160.653
PERIMETER	mm.	284.391
WEIGHT	kg/m	0.434
DRAWING No.	SECTION No.	
P-8383-2	-	
26809	26809 (ISSUE-2)	

1. ALL DIMENSIONS ARE IN mm.
2. ROUND OFF ALL SHARP CORNERS WITH 0.40 mm.
3. TOLERANCES WILL BE AS PER BS:EN-755-9 UNLESS OTHERWISE SPECIFIED

PARTY'S NAME	AIR MASTER EQUIPMENTS EMRATES LLC.,U.A.E
PARTY'S DRAWING No.	AM-100 mm
ALLOY & TEMPER	6063 WP
DESCRIPTION	MISC. SECTION