

P-8696-3

26816

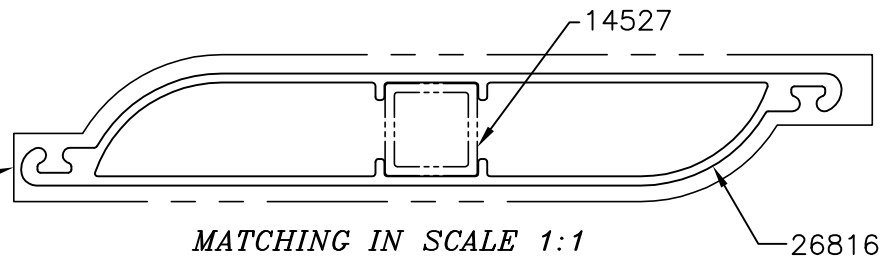

MATCHING IN SCALE 1:1

26816

EXPOSED SURFACE  
REQUIRED BETTER FINISH

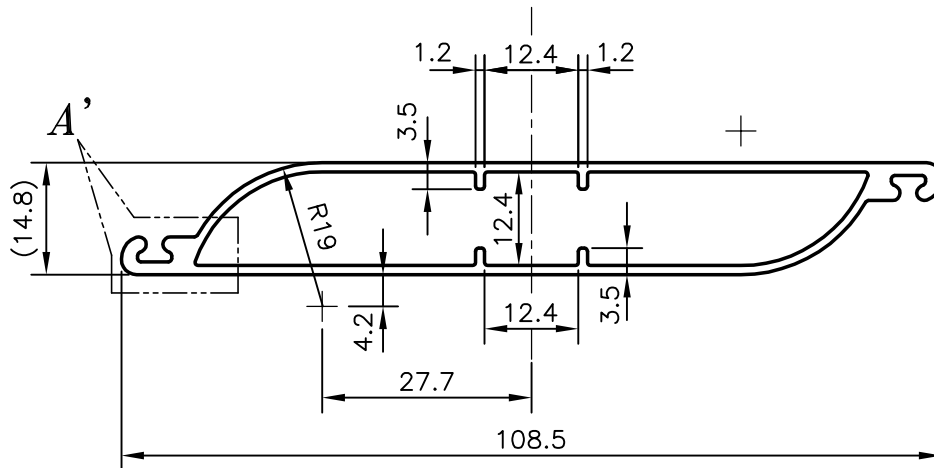

DETAIL-A

SCALE:-4:1

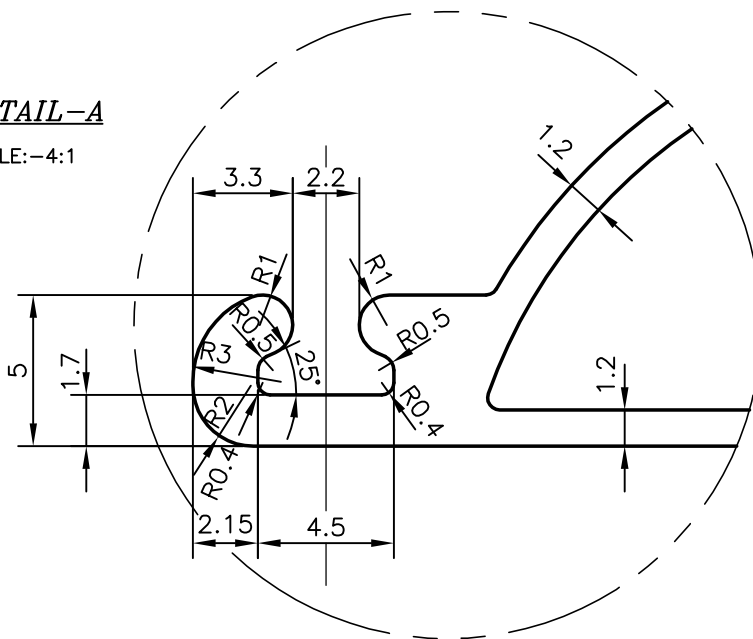

SYMBOL OF QUALITY  
AN ISO 9001 COMPANY

**JINDAL ALUMINIUM LTD.**  
BANGALORE-560073 (INDIA)

	NAME	DATE
DRAWN	ABHARANI	31-10-2008
CHECKED		
APPROVED		
SCALE		1:1
AREA mm <sup>2</sup>		306.027
PERIMETER mm.		247.565
WEIGHT kg/m		0.826
DRAWING No.	SECTION No.	
P-8696-3	-	
26816	26816	
-	-	

1. ALL DIMENSIONS ARE IN mm.
2. ROUND OFF ALL SHARP CORNERS WITH 0.4 mm.
3. TOLERANCES WILL BE AS PERIS:6477-1983 UNLESS OTHERWISE SPECIFIED

PARTY'S NAME	CLIVET TF AIR SYSTEMS(P) LTD., KOLAR
PARTY'S DRAWING No.	AS PER SAMPLE
ALLOY & TEMPER	HE9 WP
DESCRIPTION	AIR GRILL SECTION