

P-8534

26817

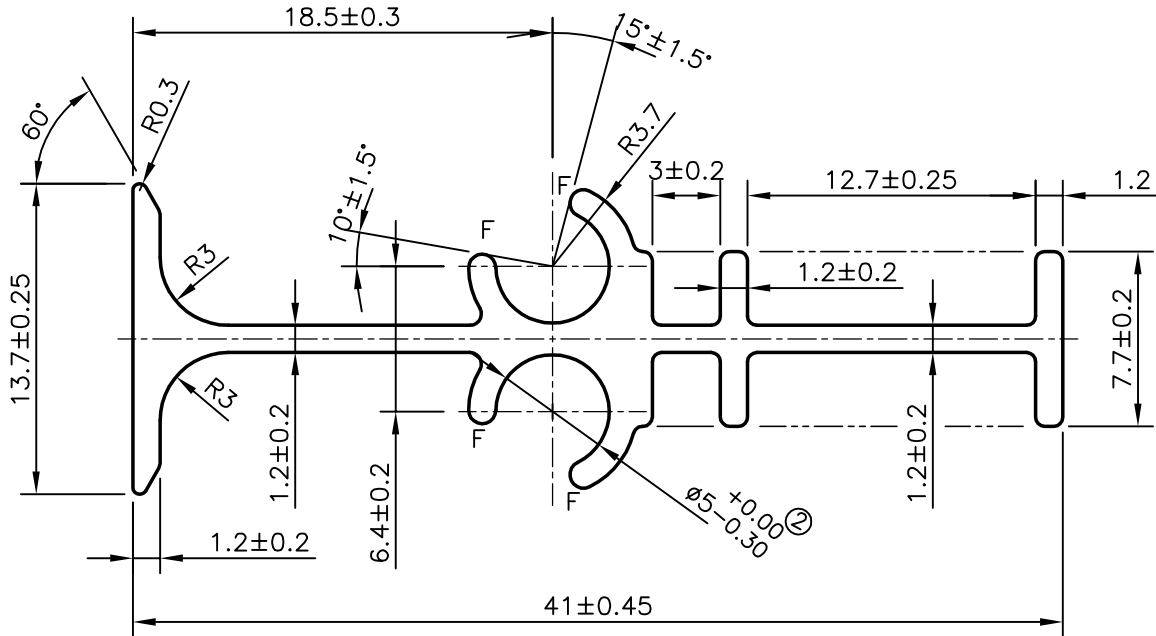
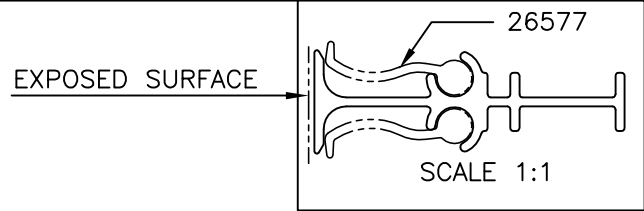

F = FULL RADIUS (4 PLACES)

Ⓜ = TOLRANCE ADDED $\phi 5.0 \begin{matrix} +0.00 \\ -0.30 \end{matrix}$



SYMBOL OF QUALITY
AN ISO 9001 COMPANY

JINDAL ALUMINIUM LTD.
BANGALORE-560073 (INDIA)

	NAME	DATE
DRAWN	J.P.KAUSHIK	24-01-2009
CHECKED		
APPROVED		
SCALE		3:1
AREA mm ²		115.169
PERIMETER mm.		161.552
WEIGHT kg/m		0.311
DRAWING No.	SECTION No.	
P-8534	-	
26817	26817(ISSUE-2)	

1. ALL DIMENSIONS ARE IN mm.
2. ROUND OFF ALL SHARP CORNERS WITH 0.40 mm.
3. TOLERANCES WILL BE AS PER IS:3965-1981 UNLESS OTHERWISE SPECIFIED

PARTY'S NAME	JAYDEE UTILITY CONSULTANTS PVT. LTD., BANGALORE
PARTY'S DRAWING No.	AS PER SAMPLE & CUSTOMER REQUIREMENT
ALLOY & TEMPER	HE9 WP
DESCRIPTION	AIR GRILL SECTION