

P-8535

26818

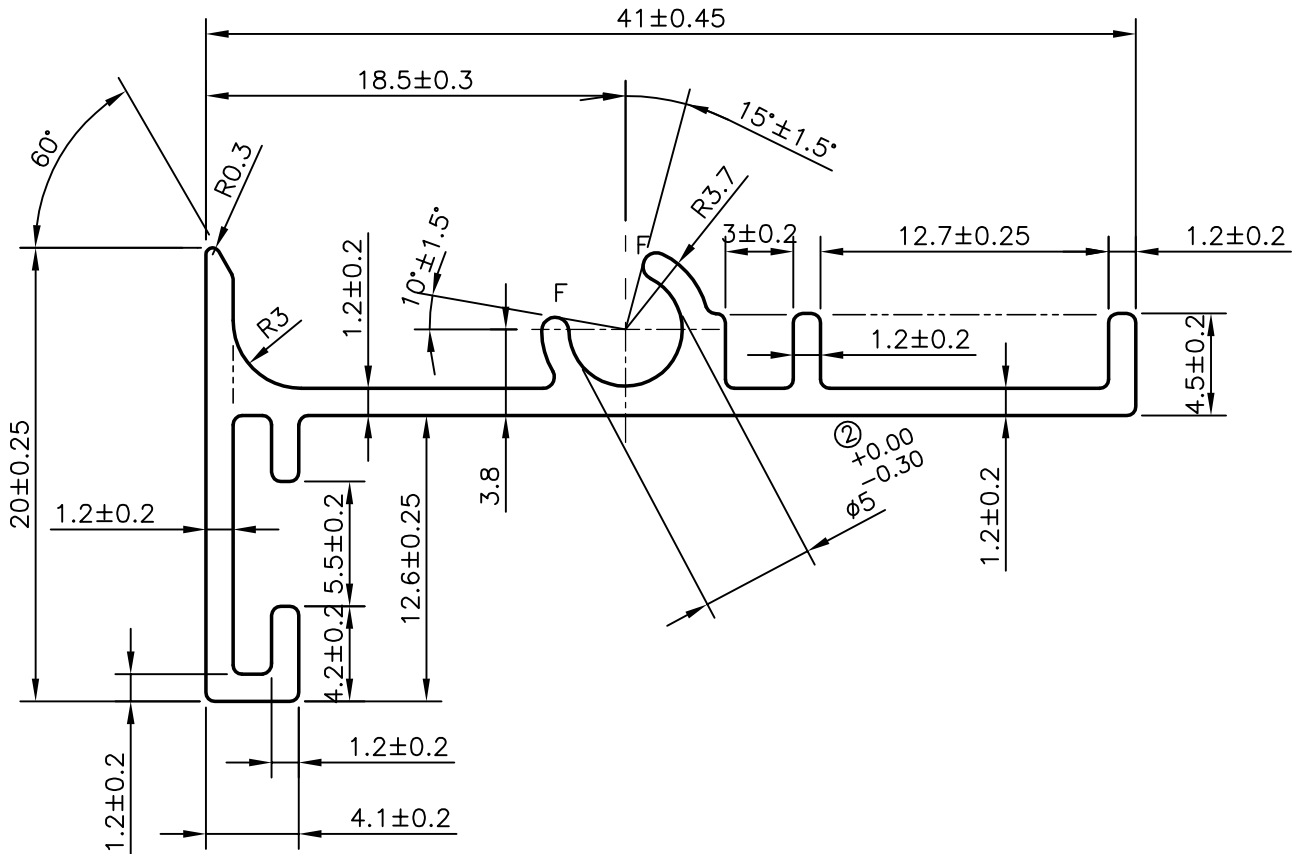
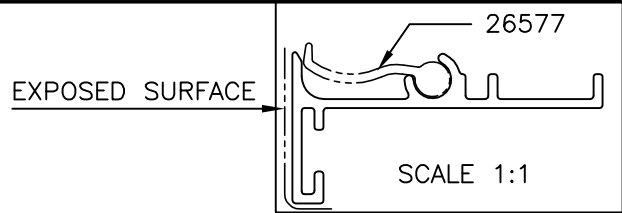

F = FULL RADIUS (2 PLACES)

② = TOLERANCE ADDED  $\phi 5.0^{+0.00}_{-0.30}$



SYMBOL OF QUALITY  
AN ISO 9001 COMPANY

**JINDAL ALUMINIUM LTD.**  
BANGALORE-560073 (INDIA)

	NAME	DATE
DRAWN	J.P.KAUSHIK	24-01-2009
CHECKED		
APPROVED		

1. ALL DIMENSIONS ARE IN mm.
2. ROUND OFF ALL SHARP CORNERS WITH 0.40 mm.
3. TOLERANCES WILL BE AS PER IS:3965-1981 UNLESS OTHERWISE SPECIFIED

SCALE	3:1
AREA mm <sup>2</sup>	107.907
PERIMETER mm.	163.797
WEIGHT kg/m	0.291

PARTY'S NAME	JAYDEE UTILITY CONSULTANTS PVT. LTD., BANGALORE
PARTY'S DRAWING No.	AS PER SAMPLE & CUSTOMER REQUIREMENT
ALLOY & TEMPER	HE9 WP
DESCRIPTION	AIR GRILL SECTION

DRAWING No.	SECTION No.
P-8535	-
26818	26818(ISSUE-2)