

P-7441-1
S2070
X987
26840

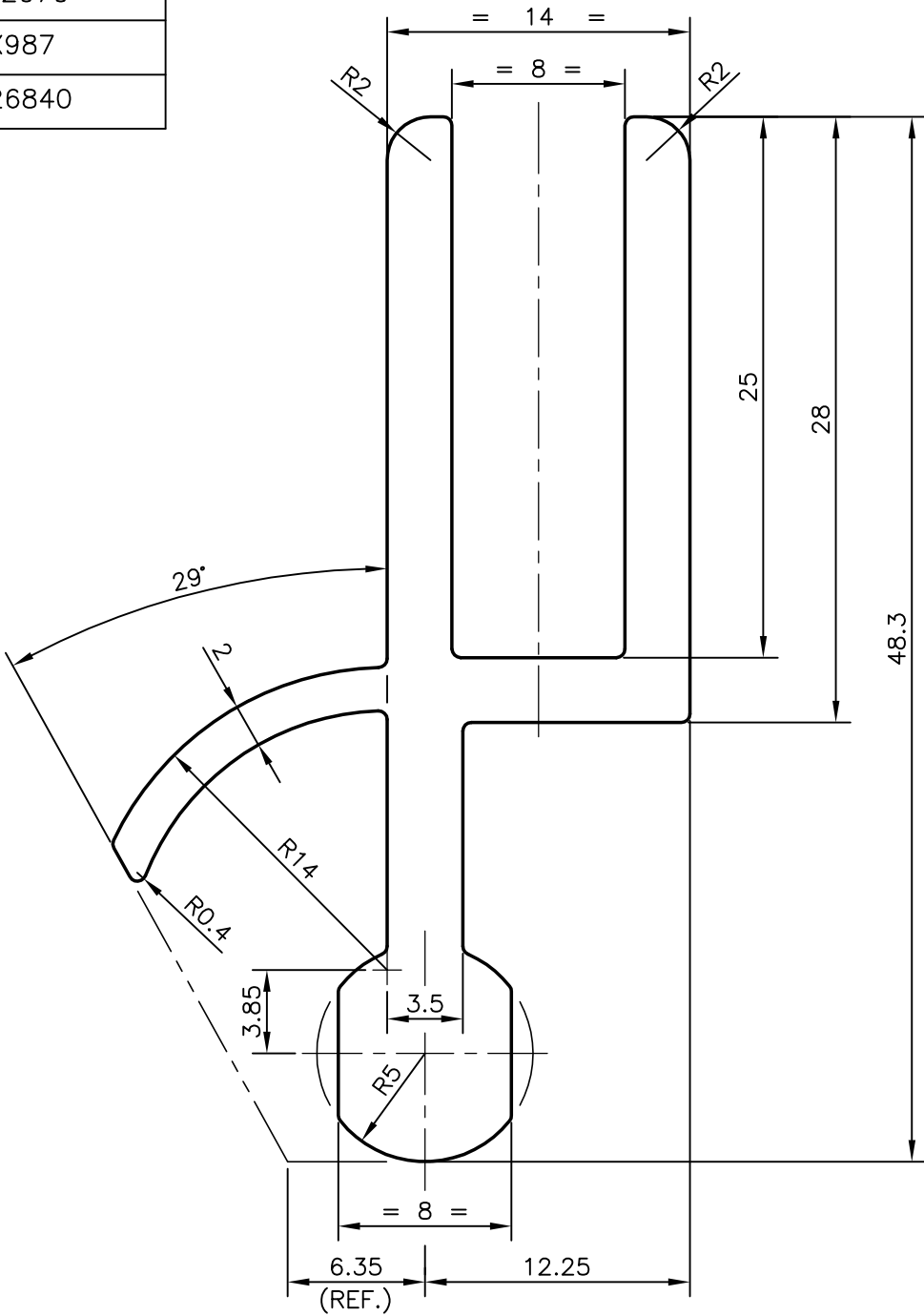
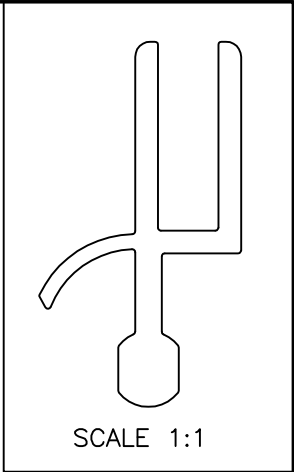

JINDAL ALUMINIUM LTD.
 BANGALORE-560073 (INDIA)

	NAME	DATE
DRAWN	PRASANN.H	21-08-2007
CHECKED		
APPROVED		

1. ALL DIMENSIONS ARE IN mm.
2. ROUND OFF ALL SHARP CORNERS WITH 0.40 mm.
3. TOLERANCES WILL BE AS PER IS:3965-1981 UNLESS OTHERWISE SPECIFIED

SCALE	3:1
AREA mm ²	328.189
PERIMETER mm.	206.401
WEIGHT kg/m	0.886

PARTY'S NAME	WILLIAMS REFRIGERATION, BANGALORE
PARTY'S DRAWING No.	AS PER DRAWING, HINGE-2
ALLOY & TEMPER	HE9 WP
DESCRIPTION	REFRIGERATION-HINGE PROFILE

DRAWING No.	SECTION No.
P-7441-1	-
S2070	S2070
X987	X987
26840	26840