

P-9785

26843

EXPOSED SURFACE

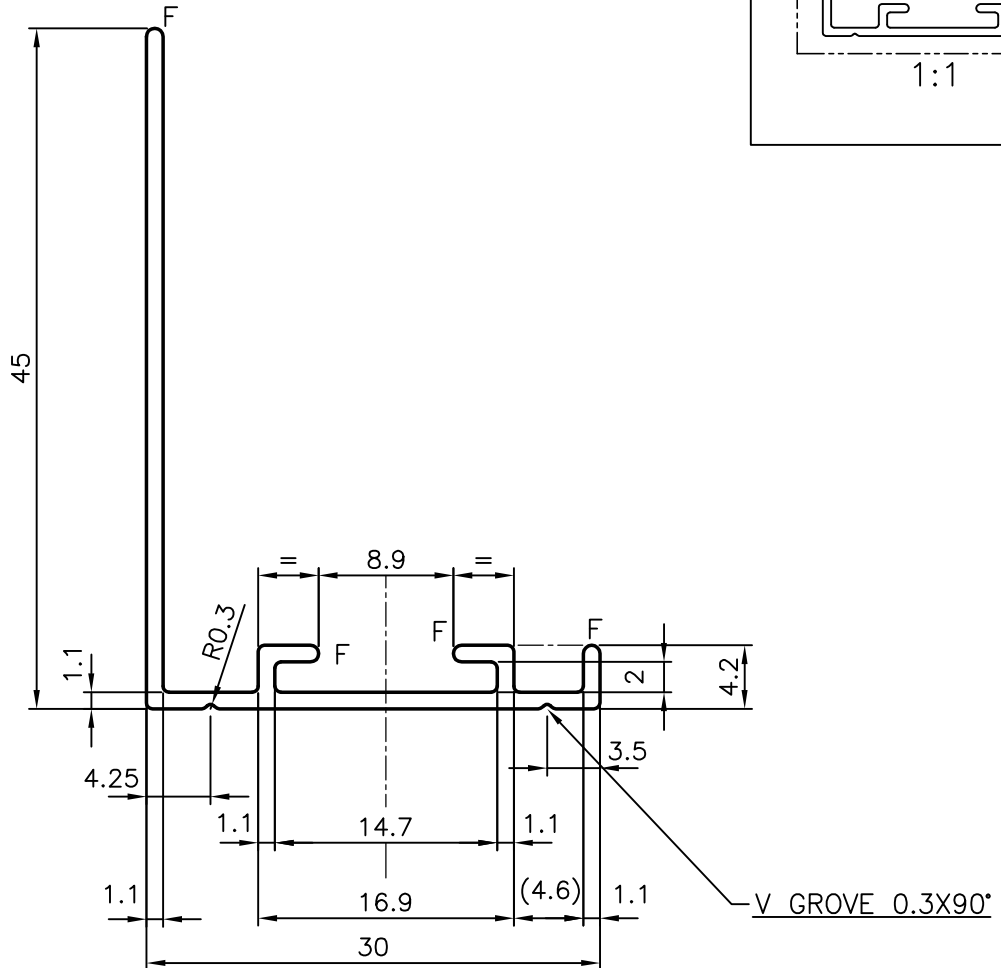

F = FULL RADIUS (4 PLACES )



SYMBOL OF QUALITY  
AN ISO 9001 COMPANY

**JINDAL ALUMINIUM LTD.**  
BANGALORE-560073 (INDIA)

	NAME	DATE
DRAWN	J.P.KAUSHIK	06-02-2010
CHECKED		
APPROVED	S.S.GARG	03-04-2010
SCALE		2:1
AREA mm <sup>2</sup>		97.184
PERIMETER mm.		176.63
WEIGHT kg/m		0.262
DRAWING No.	SECTION No.	
P-9785		
26843	26843	

1. ALL DIMENSIONS ARE IN mm.
2. ROUND OFF ALL SHARP CORNERS WITH 0.40 mm.
3. TOLERANCES WILL BE AS PER BS:EN-755, UNLESS OTHERWISE SPECIFIED

PARTY'S NAME	DASCO DUCTING & SERVICING CO.,KUWAIT
PARTY'S DRAWING No.	AS PER DRAWING
ALLOY & TEMPER	6063 T6
DESCRIPTION	AIR GRILL SECTION