

P-9751

26844

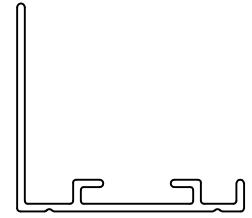

1:1

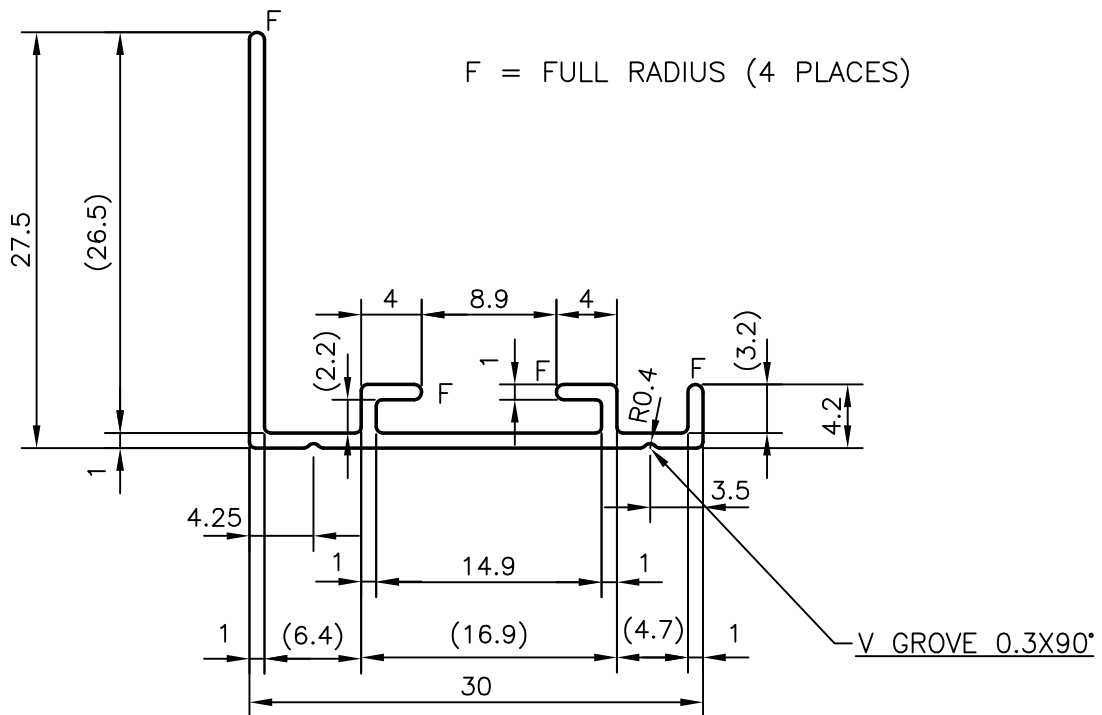

SYMBOL OF QUALITY  
AN ISO 9001 COMPANY

**JINDAL ALUMINIUM LTD.**  
BANGALORE-560073 (INDIA)

	NAME	DATE
DRAWN	J.P.KAUSHIK	15-01-2010
CHECKED		
APPROVED	J.N. RAI	09-04-2010
SCALE		2:1
AREA mm <sup>2</sup>		71.429
PERIMETER mm.		142.782
WEIGHT kg/m		0.193
DRAWING No.	SECTION No.	
P-9751	-	
26844	26844	

1. ALL DIMENSIONS ARE IN mm.
2. ROUND OFF ALL SHARP CORNERS WITH 0.40 mm.
3. TOLERANCES WILL BE AS PER BS:EN-755, UNLESS OTHERWISE SPECIFIED

PARTY'S NAME	DASCO DUCTING & SERVICES, KUWAIT
PARTY'S DRAWING No.	LIGHTER OF 26615
ALLOY & TEMPER	6063 T6
DESCRIPTION	AIR GRILL SECTION