

P-10319

26856

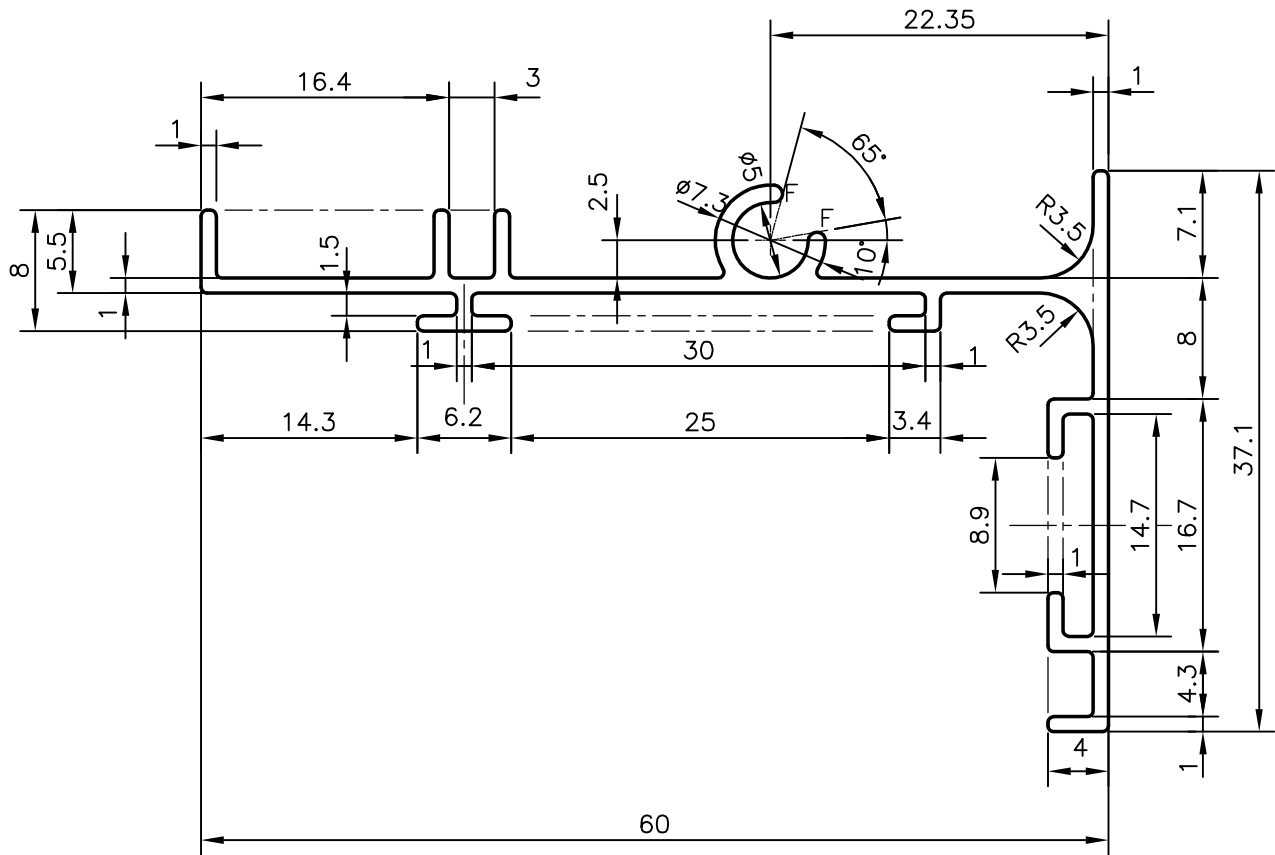

GENERAL WALL THICKNESS 1.0 mm (TYP)
 F = FULL RADIUS (2 PLACES)

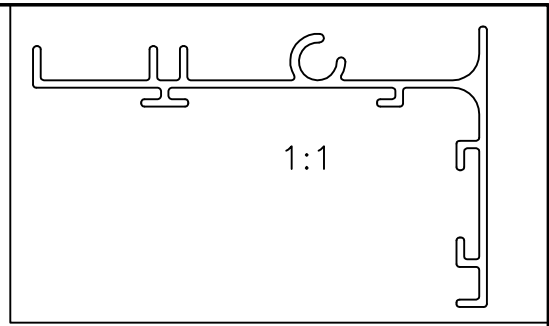

SYMBOL OF QUALITY
 AN ISO 9001 COMPANY

JINDAL ALUMINIUM LTD.
 BANGALORE-560073 (INDIA)

	NAME	DATE
DRAWN	J.P.KAUSHIK	16-08-2010
CHECKED		
APPROVED	S.S.GARG	20-08-2010
SCALE		2:1
AREA mm ²		156.007
PERIMETER mm.		285.685
WEIGHT kg/m		0.421

1. ALL DIMENSIONS ARE IN mm.
2. ROUND OFF ALL SHARP CORNERS WITH 0.4 mm.
3. TOLERANCES WILL BE AS PER BS:EN-755 UNLESS OTHERWISE SPECIFIED

PARTY'S NAME	EASA HUSAIN AL-YOUSIFI & SONS CO., KUWAIT
PARTY'S DRAWING No.	AS PER DRAWING
ALLOY & TEMPER	6063 T6
DESCRIPTION	AIR GRILL SECTION

DRAWING No.	SECTION No.
P-10319	-
26856	26856