

P-8617-1

X1028

26857

DETAIL OF "A"  
SCALE 5:1

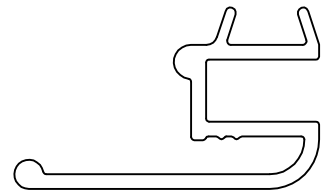
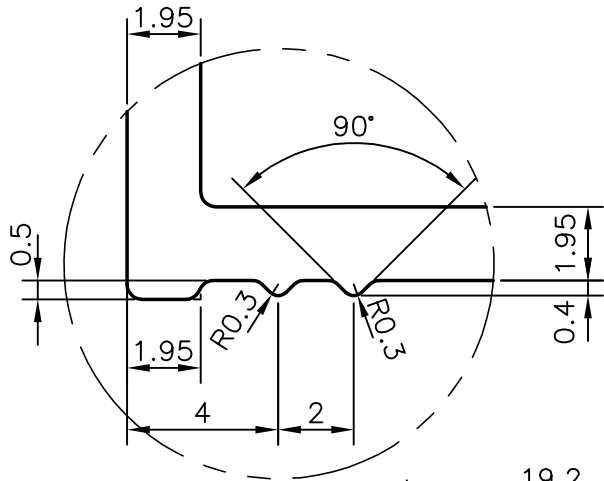

SCALE 1:1

A = R 0.50 RADIUS (2 PLACES)  
F = FULL RADIUS (2 PLACES)

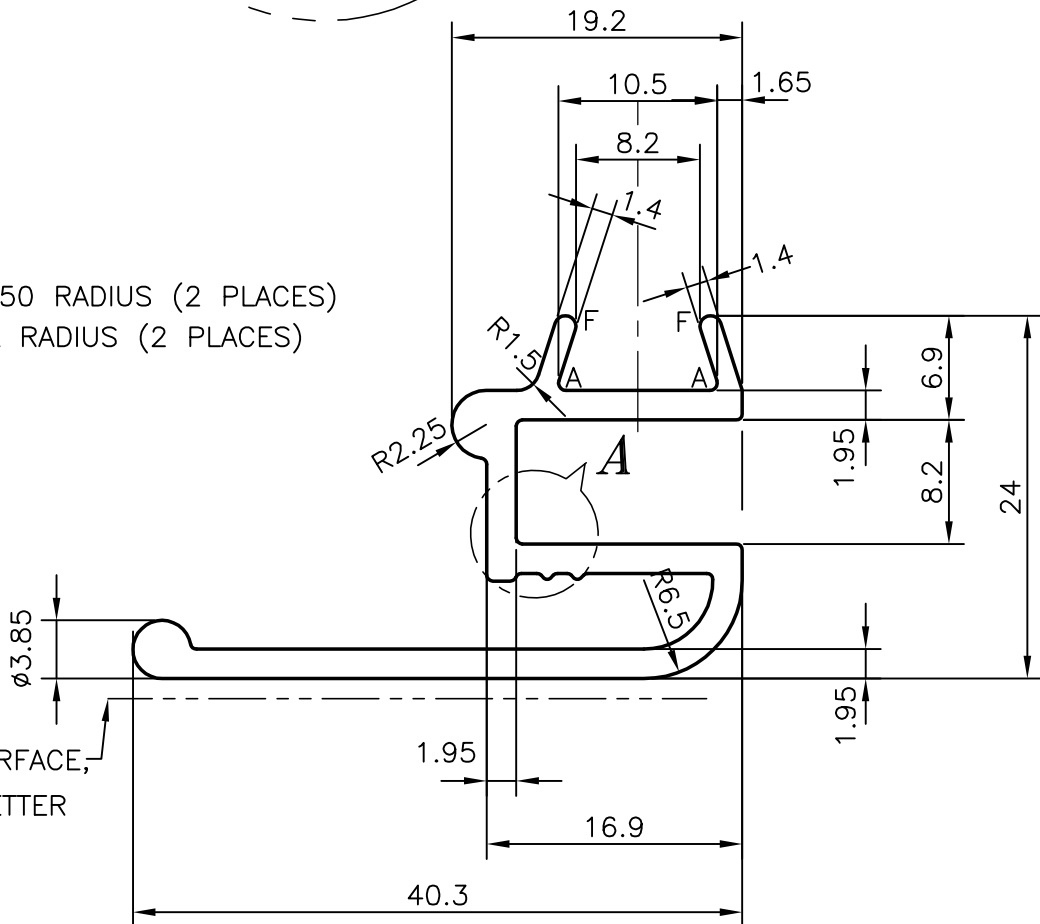

EXPOSED SURFACE,  
REQUIRED BETTER  
FINISH



SYMBOL OF QUALITY  
AN ISO 9001 COMPANY

**JINDAL ALUMINIUM LTD.**  
BANGALORE-560073 (INDIA)

	NAME	DATE
DRAWN	ABHARANI	27-09-2008
CHECKED		
APPROVED		

1. ALL DIMENSIONS ARE IN mm.
2. ROUND OFF ALL SHARP CORNERS WITH 0.40 mm.
3. TOLERANCES WILL BE AS PER IS:3965-1981 UNLESS OTHERWISE SPECIFIED

SCALE	2:1
AREA mm <sup>2</sup>	194.739
PERIMETER mm.	195.849
WEIGHT kg/m	0.526

PARTY'S NAME	WILLIAMS REFRIGERATION, BANGALORE
PARTY'S DRAWING No.	AS PER SAMPLE
ALLOY & TEMPER	6060 T6
DESCRIPTION	REFRIGERATION SECTION

DRAWING No.	SECTION No.
P-8617-1	-
X1028	X1028
26857	26857