

P-9177

S2132

26869

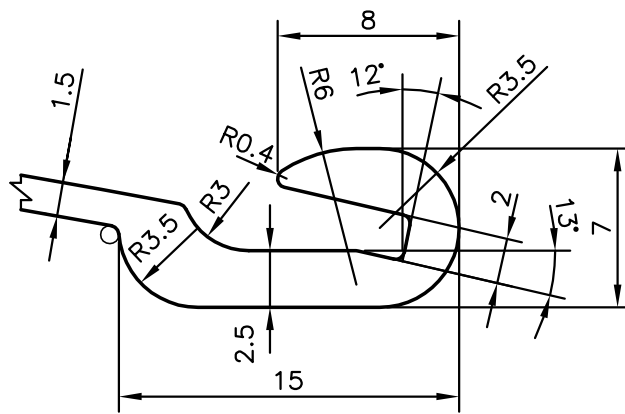

DETAIL OF "A"  
SCALE 3:1

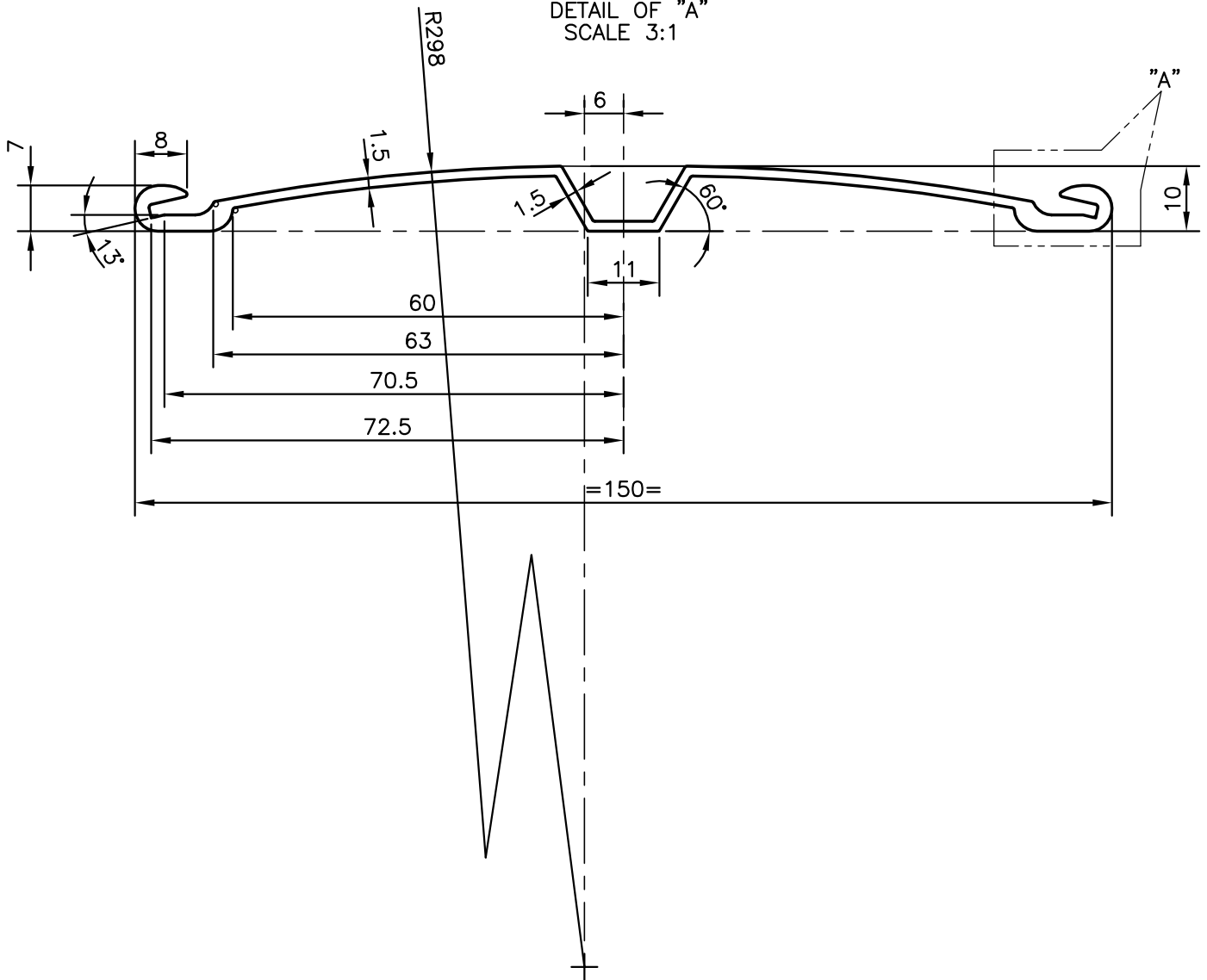

SYMBOL OF QUALITY  
AN ISO 9001 COMPANY

**JINDAL ALUMINIUM LTD.**  
BANGALORE-560073 (INDIA)

	NAME	DATE
DRAWN	J.P.KAUSHIK	21-04-2009
CHECKED		
APPROVED		

1. ALL DIMENSIONS ARE IN mm.
2. ROUND OFF ALL SHARP CORNERS WITH 0.40 mm.
3. TOLERANCES WILL BE AS PER IS:3965-1981 UNLESS OTHERWISE SPECIFIED

SCALE	1:1
AREA mm <sup>2</sup>	314.633
PERIMETER mm.	361.891
WEIGHT kg/m	0.850

PARTY'S NAME MAHI ENTERPRISE, MUMBAI

PARTY'S DRAWING No. SS 001-A

ALLOY & TEMPER HE9 WP

DESCRIPTION SINGLE SIDE-SECTION

DRAWING No.	SECTION No.
P-9177	-
S2132	S2132
26869	26869