

P-11600

26873

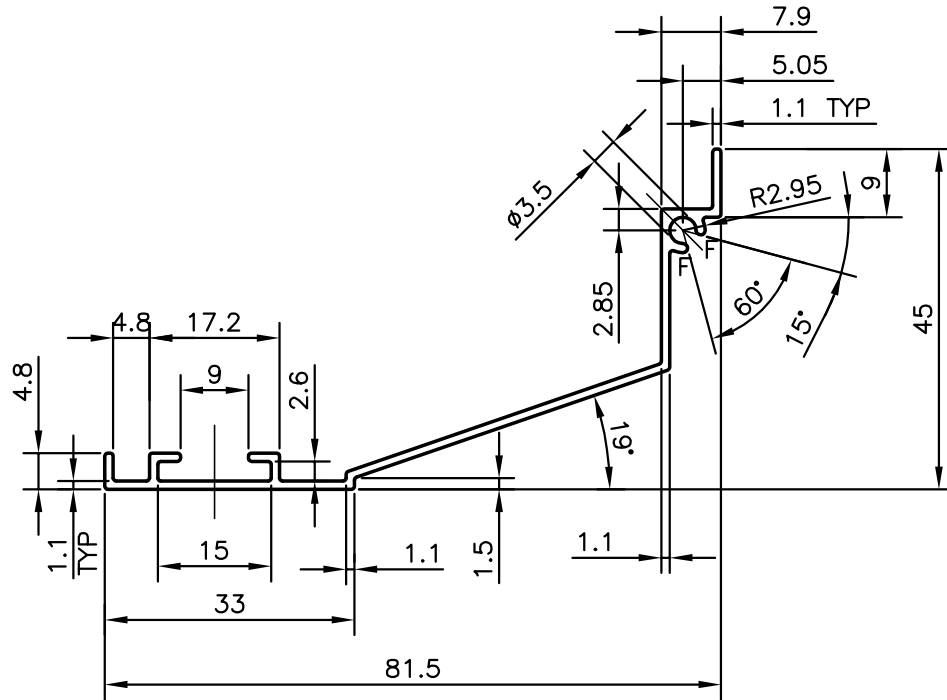

GENERAL WALL THICKNESS = 1.10mm
 F = FULL RADIUS (2 PLACES)



SYMBOL OF QUALITY
 AN ISO 9001 COMPANY

JINDAL ALUMINIUM LTD.
 BANGALORE-560073 (INDIA)

	NAME	DATE
DRAWN	RAGHAVENDRA	19-03-2012
CHECKED		
APPROVED	S.S.GARG	05-04-2012

1. ALL DIMENSIONS ARE IN mm.
2. ROUND OFF ALL SHARP CORNERS WITH 0.40 mm.
3. TOLERANCES WILL BE AS PER BS:EN-755-9 UNLESS OTHERWISE SPECIFIED

SCALE	1:1
AREA mm ²	150.309
PERIMETER mm.	265.495
WEIGHT kg/m	0.406

PARTY'S NAME THE CENTRAL INDUSTRIES & AIRCONDITIONING WORKS CO., KUWAIT

DRAWING No.	SECTION No.
P-11600	-
26873	26873

PARTY'S DRAWING No. SECTION NO. 0111

ALLOY & TEMPER 6063 T6

DESCRIPTION AIR GRILL SECTION