

P-5051-1

26881

EXPOSED SURFACE

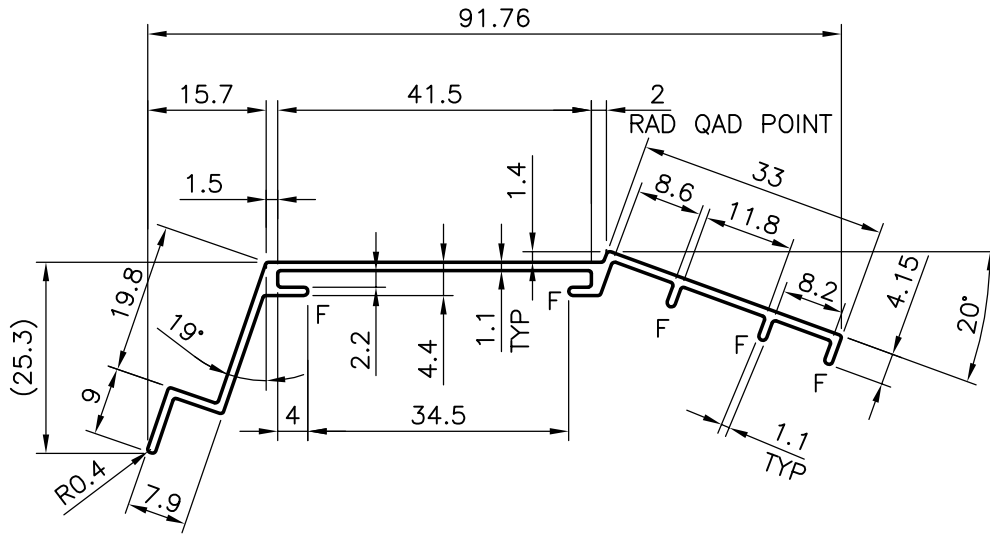
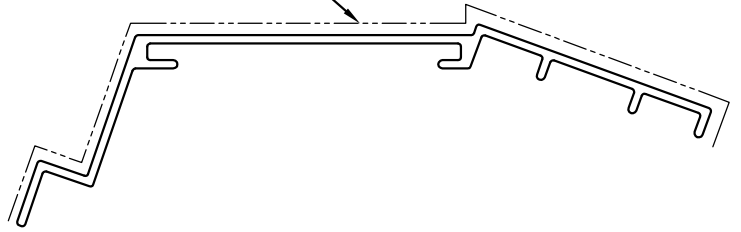

GENERAL WALL THICKNESS = 1.10mm
F = FULL RADIUS (5 PLACES)



SYMBOL OF QUALITY
AN ISO 9001 COMPANY

JINDAL ALUMINIUM LTD.
BANGALORE-560073 (INDIA)

	NAME	DATE
DRAWN	J.P.KAUSHIK	05-02-2010
CHECKED		
APPROVED	S.S.CARG	13-03-2013

1. ALL DIMENSIONS ARE IN mm.
2. ROUND OFF ALL SHARP CORNERS WITH 0.40 mm.
3. TOLERANCES WILL BE AS PER BS:EN-755, UNLESS OTHERWISE SPECIFIED

SCALE	1:1
AREA mm ²	152.508
PERIMETER mm.	262.725
WEIGHT kg/m	0.412

PARTY'S NAME	DASCO DUCTING & SERVICING CO. W.L.L
PARTY'S DRAWING No.	12394
ALLOY & TEMPER	6063 T6
DESCRIPTION	AIR GRILL SECTION

DRAWING No.	SECTION No.
P-5051-1	-
26881	26881