

P-14630

26898

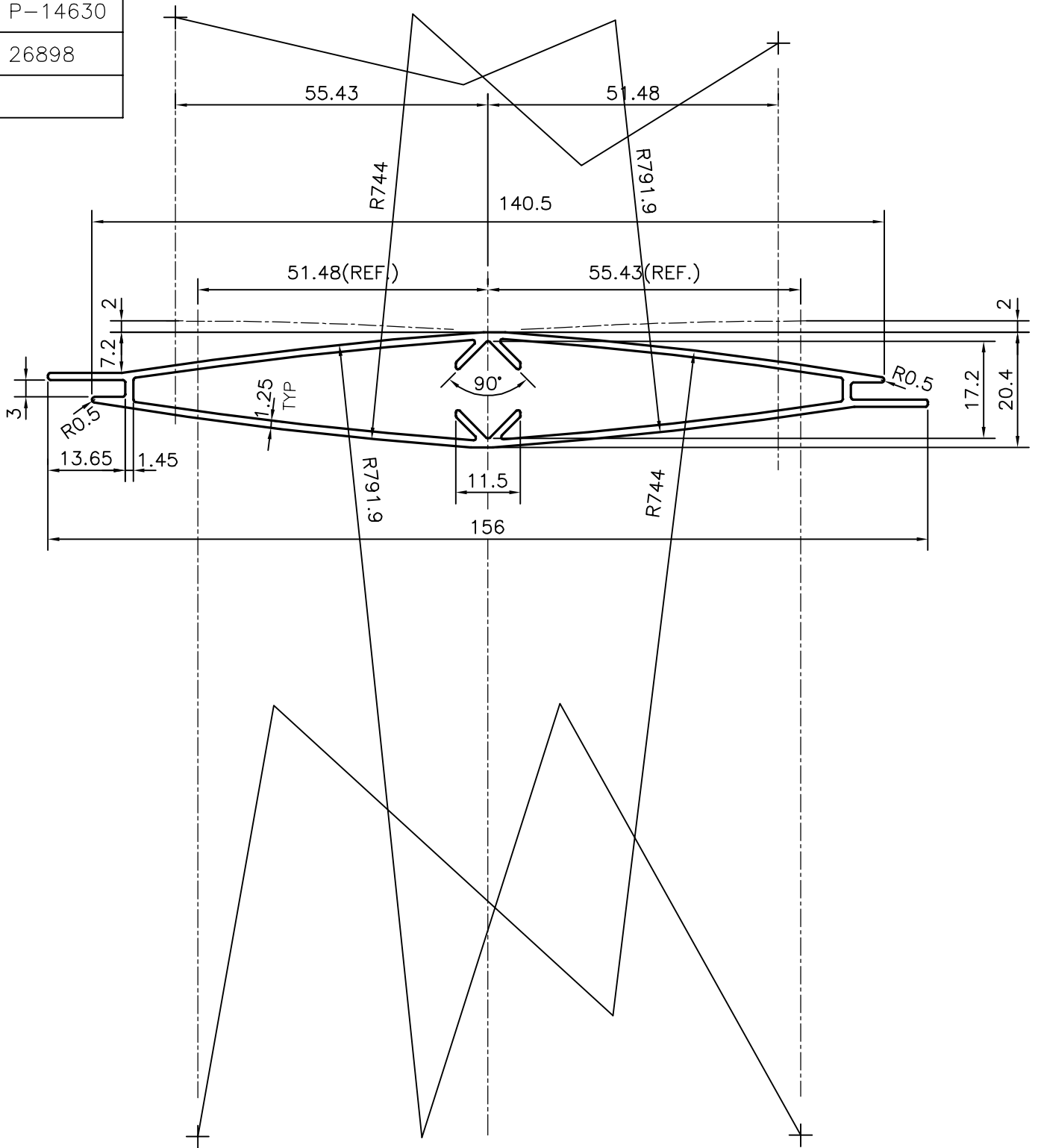

SYMBOL OF QUALITY  
AN ISO 9001 COMPANY

**JINDAL ALUMINIUM LTD.**  
BANGALORE-560073 (INDIA)

	NAME	DATE
DRAWN	J.P.KAUSHIK	07-05-2015
CHECKED		
APPROVED	S.S.GARG	01-06-2015
SCALE		1:1
AREA mm <sup>2</sup>		421.352
PERIMETER mm.		345.699
WEIGHT kg/m		1.138

1. ALL DIMENSIONS ARE IN mm.
2. ROUND OFF ALL SHARP CORNERS WITH 0.40 mm.
3. TOLERANCES WILL BE AS PER,BS:EN-755-9 UNLESS OTHERWISE SPECIFIED

PARTY'S NAME	KBE INTERNATIONAL SAL LEBANON,MIDDLE EAST	DRAWING No.	P-14630	SECTION No.	-
PARTY'S DRAWING No.	AS PER DRAWING		26898		26898
ALLOY & TEMPER	6063 T6				
DESCRIPTION	MISC. SECTION				